



Shaping the future landscape

Annual Report 2016

Shaping the future landscape

We at Overseas Realty (Ceylon) PLC have always been in the forefront, shaping the landscape of Colombo. We introduced projects, which have been iconic as the “Best Business Address” and “City within the City”.

As we venture forth, in adding value to our developments we strive to shape the future of Colombo’s landscape by transforming the real estate arena with futuristic designs and amenities.

Contents

Financial Highlights		4
Chairman's Review		8
Profiles of Directors		10
Key Events		14
Management Review (<i>Property Leasing</i>)		16
Management Review (<i>Property Trading</i>)		18
Management Review (<i>Property Services</i>)		20
Financial Review		22
Sustainability Report		26
Risk Management Report		30
Corporate Governance Report		32
Remuneration Committee Report		50
Audit Committee Report		51
Related Party Transactions Review Committee Report		53

FINANCIAL REPORTS

Financial Calendar		54
Annual Report of the Board of Directors		56
Directors, Statement on Internal Controls		61
Directors' Responsibility for Financial Reporting		62
Independent Auditors' Report		63
Statement of Financial Position		64
Statement of Profit or Loss		65
Statement of Comprehensive Income		66
Statement of Changes in Equity		67
Statement of Cash Flows		68
Notes to the Financial Statements		69
Group Performance - Ten Year Summary		116
Shareholder Information		118
Group Land Portfolio		122
Notice of Meeting		123
Corporate Information		Inner Back Cover

Our Vision

Our passion is to be the most successful and innovative real estate solutions provider in the region.

Our Mission

To be a truly Sri Lankan, self-contained, diversified, real estate solutions provider, driven by a highly motivated professional team to exceed the expectations of customers and shareholders.

Our Values

Customer Oriented

Quality

Team Work

Honesty

Continuous Learning

Innovation

Accountability

Respect

Sense of Urgency

Financial Highlights

For the year ended 31st December	2016 Rs Mn	2015 Rs Mn
INCOME STATEMENT		
Revenue	2,431	3,141
Gross Profit	1,656	1,940
Fair Value Gain (FVG)	1,267	1,175
Profit Before Tax (PBT)	2,974	3,073
Profit After Tax (PAT)	2,930	3,031
PAT (Excluding FVG)	1,663	1,856
STATEMENT OF FINANCIAL POSITION		
Total Assets	34,181	32,274
Total Liabilities	6,348	2,157
Loans and Borrowings	2,304	96
SHAREHOLDERS' EQUITY		
Stated Capital	11,163	11,163
Reserves	16,671	17,442
FINANCIAL RATIOS		
Gross Profit Margin	68%	62%
PAT (Including FVG) Margin	121%	96%
PAT (Excluding FVG) Margin	68%	59%
Earnings Per Share (Including FVG)	3.28	3.44
Earnings Per Share (Excluding FVG)	1.85	2.09
Return on Equity	10%	11%
Debt Equity Ratio	8.3%	0.3%
Net Assets Per Share	31.35	32.22
PE Ratio	6.1	6.7

Group Revenue

Rs. **2,431** Mn

Group Profit
after tax PAT

Rs. **2,930** Mn

Group Revenue (Rs Mn)

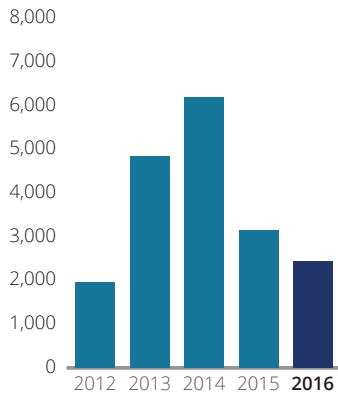

Group Profit After Tax (Rs Mn)

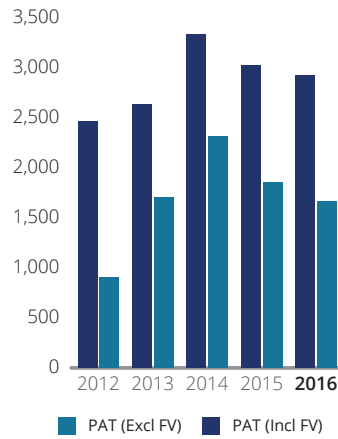

Earning Per Share (Rs)

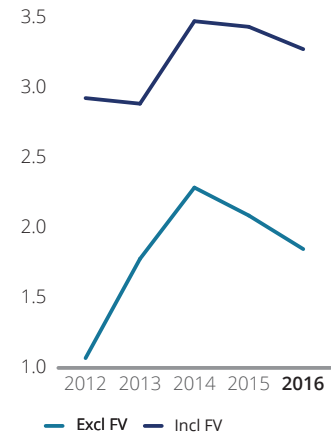

NAVPS vs. Avg. Share Price (Rs)

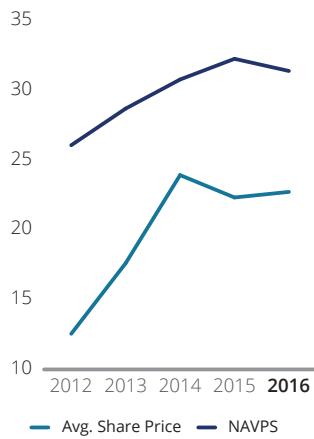

ROE and ROA (%)

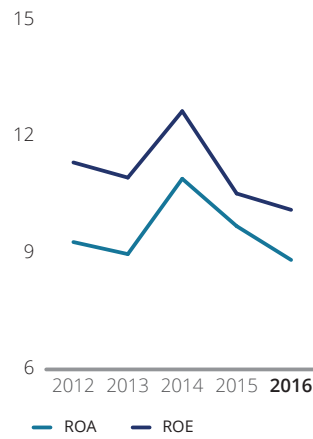

Shareholders Equity and Total Assets (Rs Mn)

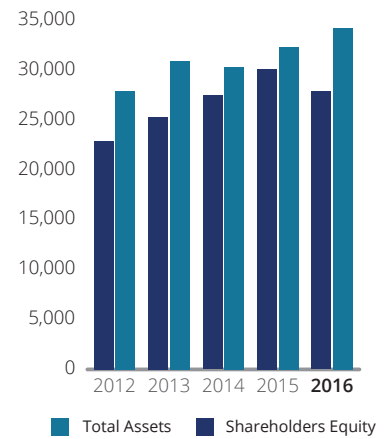

Total Assets

Rs. **34,181** Mn

Earning Per Share

Rs. **3.28**



We expect the WTC to continue to provide a solid foundation as the Company embarks on the next phase of its expansion. The Havelock City is the largest integrated mixed-use real estate development project conceptualized and developed in Sri Lanka.



Chairman's Review

"Your Company reinforced its position as the premier property owning, development and management company in Sri Lanka by accelerating the Havelock City Commercial project with a symbolic ground breaking of its commercial development on 28 December 2016."



On behalf of the Board of Directors I am pleased to present the Annual Report and Financial Statements for the Year ended 31st December 2016 and also to warmly welcome my fellow Shareholders to the 35th Annual General Meeting of Overseas Realty (Ceylon) PLC.

Your Company reinforced its position as the premier property owning, development and management company in Sri Lanka by accelerating the Havelock City Commercial project with a symbolic ground breaking of its commercial development on 28 December 2016.

Economic Outlook

The Sri Lankan economy grew by 4.4% in 2016 compared to 4.8% in 2015. Interest rates increased by around

3% during the year while inflation remained at single digits. The Sri Lanka Rupee depreciated by 4% against the US Dollar. The performance of the Company within this economic environment was noteworthy.

Financial Performance

With a challenging operating environment in the year under review, your Company recorded a marginal decrease in revenue while Group Revenue decreased by 23% to Rs 2,431 Mn due mainly to non-recognition of Havelock City Residential Phase 3 revenue. Consequently, group operating profit declined by 7% to Rs 2,600 Mn.

However, the Company's profit before tax was higher than last year due to higher interest income. Group profit

before tax was marginally lower than last year due mainly to non-recognition of Havelock City Residential Phase 3 revenue.

World Trade Centre (WTC)

The World Trade Centre continues to perform well providing recurring income for the Company. Despite a relatively weaker macro environment, the Company managed to sustain rental income amid a slight decrease in occupancy. The Company maintains its leadership position in built quality, facilities and services by continually upgrading the systems and facilities in the Building. The standby power capacity of the building was upgraded to enable uninterrupted power supply in the event of disruption to the main grid power supply. The Company also

“The Company bought the 40% shareholding in MCL, Owner of the Havelock city project, held by its original Joint Venture Partner, Bank of Ceylon, for a total consideration of Rs. 3.880 Bn on 30th December 2016.”

initiated a modernization programme which will be implemented during 2017/18.

We expect the WTC to continue to provide a solid foundation as the Company embarks on the next phase of its expansion.

Havelock City

Havelock City is the largest integrated mixed-use real estate development project conceptualized and developed in Sri Lanka.

Mireka Capital Land (Pvt) Ltd (MCL)

The Company bought the 40% shareholding in MCL, Owner of the Havelock city project, held by its original Joint Venture Partner, Bank of Ceylon, for a total consideration of Rs 3.880 Bn

on 30th December 2016. This makes MCL a wholly owned subsidiary of the Company.

Residential component

The Havelock City Residential development is built in four Phases. Phases 1 and 2 comprise 445 luxury apartments that have been successfully built and sold. Phases 3 and 4 comprising 644 beautifully designed condominium units are under construction. By the end of 2016, 31% of the Phase 3 units were pre-sold while Phase 4 is yet to be launched.

Commercial component

A ceremonial ground breaking and inauguration ceremony of the Commercial mixed use complex was held on 28 December 2016. This is a BOI approved Project with an investment of approx. USD 166 Mn.

On completion, in 2020, it will boast a landmark 46 storied office building of 600,000 sq ft and a 200,000 sq. ft. shopping mall on carefully designed hardscape which will visually anchor the Havelock City residences.

Rights Issue

The Rights Issue of two (02) ordinary shares for every five (05) totaling to 355,151,309 new ordinary Shares at a price of Rs 20.5 per Share was successfully concluded raising Rs 7.3 Bn. The Rights Issue proceeds will be utilized for the proposed Havelock City Commercial Development. Part of the proceeds are recommended to be used to repay the loan of USD 13 Mn obtained to acquire the BOC stake in MCL.

The Company is of the strong view that Sri Lankan economy will do well. Hence the decision to enter into this period of investment for future growth

I wish to thank our valued Shareholders for the confidence placed in the Company and subscribing to the Rights Issue.

Dividends

Your Board recommended a first and final dividend of Rs 1.25 per share on the enhanced Share Capital for the year 2016. Accordingly, the total payout for the year under review would be Rs 1,554 Million compared to Rs 1,265 Mn last year.

Acknowledgement

On behalf of the Board of Directors I would like to express my appreciation to our loyal Shareholders, Business Partners, Customers and Tenants for their continuous support during the year. I also thank the Management and Staff for their dedication and hard work in contributing to the growth of the Group. Finally, I extend my gratitude to my Board Members for their expert guidance and professional contribution extended to the Group.



S.P. Tao
Chairman

09th February 2017

Profiles of Directors

Mr. Shing Pee Tao

Mr. Shing Pee Tao is the Founder of the Shing Kwan Group. A naturalized citizen of Singapore of Chinese origin, Mr. Tao has extensive worldwide business experience and is widely regarded as a visionary entrepreneur in the commodities, shipping and real estate sectors. Mr. S.P Tao has been the non-executive Chairman of the Company since the Shing Kwan Group invested in the Company in 1991.

Mr. S P Tao commenced his business association with Sri Lanka in 1958 dealing in commodities and shipping with the Ceylon Food Commissioner's office. In the 1970's, he assisted Sri Lanka to establish the Ceylon National Shipping Corporation when he sold one ship, on credit, to the Shipping Corporation which was renamed "Lanka Rani". Pursuant to that, as payment, he received a 20% equity share in Colombo Dockyard.

In 1991, Mr. Tao, in assisting the Keppel Group of Singapore to negotiate and acquire Colombo Dockyard, revisited Colombo and thus renewed his acquaintances and re-visited friends of some 20 years.

Attracted by the incentives offered by the Sri Lanka Government and on the recommendation of his old friend, the then Chairman of National Development Bank, Mr. Baku Mahadeva, Mr. Tao acquired Overseas Realty (Ceylon) PLC (ORC PLC), a listed Company on the Colombo Stock Exchange, owning an undeveloped plot of land at Echelon Square in the Colombo Fort area.

Mr. Tao then decided on a monumental investment in Sri Lanka, for his legacy, in developing the World Trade Center

(WTC) Twin Towers, which at the time was years ahead of any commercial development in the country. To ensure the highest standards of quality that would withstand the test of time, he also invited the world's leading construction company, Turner Steiner of USA, to construct the Twin Towers.

Apart from Sri Lanka, Mr. Tao has real estate investments principally in China and Singapore. Between 1972 and 1996, he was Chairman of Singapore Land Limited spearheading its growth into the largest listed property company on the Singapore Stock Exchange. During this time, he conceptualized and developed the iconic Marina Square complex which paved the way for development in downtown Singapore. Mr. Tao was also a co-founder of PT Jakarta Land, developer and owner of the World Trade Center complex in Jakarta, Indonesia and served on its Board from 1980 to 2005.

Mr. Hussein Zubire Cassim

Appointed to the Board as a non-executive Director of ORC PLC in April 1991, Mr. Hussein Zubire Cassim presently serves as the Deputy Chairman of the Board and a Member of the Audit Committee and Remuneration Committee. He is an Associate Member of the Institute of Chartered Ship Brokers, London, having qualified in the Inter-arts Examination, London, in 1950. Mr. Cassim held the post of Secretary to the Minister of Trade, Commerce & Tourism from 1952 to 1956. He was appointed General Manager of Ceylon Shipping Lines in 1958 and held this post until 1963. He was the Chairman of HZ Cassim & Co Shipping Agents from 1963 to 1971 till he relocated to Singapore. From 1960

to date he has held executive and non-executive directorates in Singapore and Sri Lanka.

Mr. Cassim was also a member of the Panel of Advisors of the United Nations Youth Federation of Sri Lanka from May 1999 to 2004. He was the first President of the Sri Lanka - Singapore Business Council, an affiliate of the Ceylon Chamber of Commerce. He held this post for two consecutive years. He was also a member of the Executive Committee of the Ceylon Chamber of Commerce.

Mrs. Mildred Tao Ong (Dr.)

Mrs. Mildred Ong was appointed to the Board as a non-executive Director in 1991. She received her MBBS from University College London in 1972 and MRCP (UK) in Pediatrics in 1975. She however gave up medical practice to join the Shing Kwan Group in 1977 where she has been actively involved in all aspects of the Group's property portfolio encompassing the residential, commercial and retail sectors through its controlling interest in Singapore Land Limited (until 1990), P T Jakarta Land (until 2005) and ORCPLC. Mrs. Ong participated in the Advanced Management Program in Harvard Business School in 1983.

Mrs. Ong currently oversees the Shing Kwan Group's real estate investments in Singapore and abroad.

Mr. Yap Boh Pin

Mr. Yap Boh Pin was appointed as a non-executive Director of the Company on April 1991 and was a member of the Executive Committee of the Board until 18th January 2010. Mr. Yap serves

as a member of the Company's Audit Committee from November 1996.

Mr. Yap qualified as a chartered accountant from the Institute of Chartered Accountants in England and Wales in 1966. He is a fellow member of both the Institute of Chartered Accountants of Singapore, and the Institute of Chartered Accountants in England and Wales.

He is currently the Managing Director of B.P.Y. Private Limited, a firm of management consultants which provides financial planning, financial accounting, reviewing internal control systems as well as corporate secretarial services in Singapore.

Between July 1975 and January 1999, Mr. Yap was a senior partner at Yap Boh Pin & Co. which provided advice on auditing, taxation, liquidation and corporate restructuring matters. He is an independent Director of TeleChoice International Limited, a public listed company, Asia Mobile Holdings Pte Ltd and STT Communications (Beijing) Co Ltd (both are private subsidiaries of Singapore Technologies Telemedia Pte Ltd), which is part of the Singapore Technology Group. He is also the Chairman of the Audit Committee and member of the Nominating Committee for TeleChoice International Limited. He is also an independent Director of public listed company, Lereno Bio-Chem Ltd, serving as Chairman of its Audit Committee and member of its Nominating Committee.

He has also held directorships in various public companies between 1975 and 2000, including Singapore Land Limited, L&M Investments Limited and Pan Pacific Company Limited and a

member of their executive committees and/or audit committees, assisting in the evaluation and recommendation of changes to their system of internal controls and corporate governance.

Beyond the corporate sector, Mr. Yap is actively involved in various non-profit, educational and social welfare organizations. He is an Honorary Council Member of the Singapore Hokkien Huay Kuan and a member of the Audit Committee of the Chinese Development Assistance Council. He is also a Director of Anglo-Chinese School (International) and chairman of its finance Sub Committee.

Mr. Ajit Mahendra De Silva Jayaratne

Mr. Ajit M. De S. Jayaratne was re-appointed to the Board of ORC PLC in 2005 as an independent non-executive Director. Mr. Jayaratne is also the Chairman of the Audit Committee of the Company.

Mr. Jayaratne graduated from the University of Southampton, U.K. with a BSc degree in Economics. Thereafter he qualified as a Fellow of the Institute of Chartered Accountants of U.K. Returning to Sri Lanka, he became a member of the Institute of Chartered Accountants of Sri Lanka.

He served at Forbes & Walker Limited for most of his working life, culminating in being appointed as the Chairman of the company, a position he held for several years. During his period of service at Forbes & Walker, he was appointed to the Boards of several public and private companies. He also served as the Chairman of the

Colombo Stock Exchange, Chairman of the Finance Commission and Chairman of the Ceylon Chamber of Commerce. Upon retiring from the private sector, he was appointed as Sri Lanka's High Commissioner to Singapore. Upon completing his term in Singapore and returning to Sri Lanka, he continues to serve on the Boards of several public companies.

Mr. En Ping Ong

Mr. En Ping Ong was appointed to the Board of Directors of the Company on 18th January 2010. Mr. Ong graduated from Harvard University with a BA (Hons) in Applied Mathematics and later attended the Graduate School of Business at Stanford University for his MBA. He has a background in Investment Banking and is focused on growing the real estate business of Shing Kwan Group.

Mr. Leslie Ralph de Lanerolle

Mr. Ralph de Lanerolle joined the Board of Directors of ORC PLC on 3rd June 2010. Mr. de Lanerolle has over 50 years of work experience in both in the public and private sectors, where he has held senior management positions.

A Chartered Engineer, Mr. de Lanerolle holds a Bachelor's degree in Civil Engineering (First Class Honours) from the University of Ceylon (1965) and a Master's degree from the University of Waterloo, Ontario, Canada (1968). He is a member of the Association of Professional Bankers of Sri Lanka, a Fellow of the Economic Development Institute of the World Bank, Washington and a Honorary Life Member of the Institute of Engineering Sri Lanka.

Profiles of Directors

Mr. De Lanerolle has worked primarily in the field of Project Finance and Management, undertaking assignments in diverse sectors of the economy, especially in the financial services, real estate and property, tourism, hotel and transportation sectors. In an individual capacity, he has served as Consultant to several private companies, providing project related advisory services from pre-investment to implementation.

Mr. de Lanerolle is currently, a Director of ORCPLC and its group companies Mireka Capital Land (Pvt) Ltd and Mireka Homes (Pvt) Ltd. He has also served, and continues to serve, on the Board of Directors of several private and public listed companies.

Mr. Tissa Kumara Bandaranayake

Mr. Tissa Bandaranayake was appointed to the Board of directors of ORC PLC as a non-executive independent director on 19th May 2011 and he is also a member of the Audit and Remuneration Committees. A Fellow member of the Institute of Chartered Accountants of Sri Lanka Mr. Tissa Bandaranayake also holds a B.Sc. degree from the University of Ceylon.

Mr. Bandaranayake retired from Ernst & Young as senior Partner in 2009 after 27 years of Service. He is a Past Chairman of the Audit Faculty and the current Chairman of the Quality Assurance Board established by the Institute of Chartered Accountants of Sri Lanka comprising senior professional representatives from both the private sector and State Regulatory bodies.

Mr. Bandaranayake presently serves as an independent Director of Nawaloka

Hospitals PLC, Samson International PLC, Laugfs Gas PLC, Renuka Foods PLC, Renuka Holdings PLC, Micro Holdings Ltd, Harischandra Mills PLC and Brown & Company PLC. He also serves as a Consultant to the Board of Noritake Lanka Porcelain (Pvt) Ltd.

Dr. Ranee Jayamaha

B.A. (Hons) (University of Ceylon, Peradeniya, Sri Lanka), MSc (University of Stirling, U.K.), PhD (University of Bradford, U.K.), DUniv (University of Stirling, U.K.)

Dr. Ranee Jayamaha was appointed to the Board of Directors of the Company as an Independent Non-Executive Director on 15th March 2013,

Dr. Ranee Jayamaha is currently a Council member of the University of Colombo and the Lead Consultant for South Asia Region for the World Bank Group. She was the Chairperson of Hatton National Bank Plc., HNB Assurance PLC and Sithma Development (Pvt) Ltd. Dr. Jayamaha had been the Deputy Governor in charge of Financial System Stability of the Central Bank of Sri Lanka from 2004 up to her retirement at end of May 2009. She has over 40 years of extensive experience in the field of economics, banking, finance, regulation and administration, having held a number of positions in the Central Bank and outside.

On release from the Central Bank, she has served as Secretary – Presidential Commission on Finance & Banking, Advisor- Financial Sector Reform Committee, Ministry of Finance and Special Advisor (Economic) – Commonwealth Secretariat, London, UK.

She has been a member of the Securities & Exchange Commission of Sri Lanka, the Insurance Board of Sri Lanka, the Chairperson of Credit Information Bureau of Sri Lanka and the National Payments Council. Dr. Jayamaha has been a Member of the Working Group on General Payment System Development of the Bank for International Settlements, Member of the Global Payments Forum, Member of the Advisory Panel of the G-8 Remittance Working Group and Member of the Expert Panel of the Safeguard Assessment Policy Review 2010 of the IMF. She had been providing advisory services to a number of International financial Institutions and Central Banks in the Region.

Mrs. Rohini Lettitia Nanayakkara

Mrs. Rohini Nanayakkara was appointed to the Board of Directors of the Company as an independent non-executive Director in 2005. She holds a second Class BA Honours Degree from the University of Peradeniya, Sri Lanka. She also holds a Diploma in French from the Chamber of Commerce, Brussels. She is a Fellow of the Institute of Management & the Institute of Bankers, Sri Lanka. She has also been the President of the Sri Lanka Banks Association and the Association of Professional Bankers, a member of the Commission of the University of Colombo, Sri Lanka and of the Task Force setup by the Government for Tsunami reconstruction.

She was the first woman executive to join a commercial bank, namely Bank of Ceylon, eventually earning the rare distinction of becoming the first woman General Manager/CEO of the Bank, a



first for any bank in Sri Lanka and the Asian Region.

She was also Chairman/Director of several financial institutions such as the National Development Bank, DFCC Bank, Merchant Bank of Sri Lanka and the First Capital Group of Companies. She has served as Director/General Manager/CEO of one of the largest private banks namely, Seylan Bank PLC.

She was the Chairperson of the LOLC Group of Companies and the Browns Group of Companies. She is presently the Chairperson of Subsidiaries of Browns Group of Companies. She is also a Director of Eastern Merchants PLC and a trustee of the National Trust of Sri Lanka.

Mr. Pravir Samarasinghe

Mr Pravir Samarasinghe was appointed to the Board of Directors of the company with effect from 31st March 2014.

He is the Group Chief Executive Officer of ORC PLC since his appointment on 10th March 2011.

He has 30 years of professional and commercial experience and serves on the Board of Directors of several public listed and unlisted Companies.

He is a Fellow Member of the Institute of Chartered Accountants of Sri Lanka and Chartered Institute of Management Accountants UK and holds a Masters Degree in Business Administration.

He is the Chairman of the Condominium Developers Association of Sri Lanka and the EFC Affiliated Associations Group and is the Vice Chairman of the Employers Federation of Ceylon. He was the former Chairman of the Sri Lanka Institute of Directors, Industrial Association of Sri Lanka and past President CIMA Sri Lanka Division and former Council member CIMA Global.

Key Events

Sales Launch of Phase 3 Residential Development

Havelock City launched the sales of Phase 3 comprising two towers, with 304 beautifully designed apartments in March 2016.



Acquisition of SK Investments Lanka (Pvt) Ltd

The Company acquired 100% shareholding of SK Investments Lanka (Pvt) Ltd in April 2016, which owns two floors in the World Trade Center – West Tower.

Havelock City signs BOI Agreement

An agreement was signed with the Board of Investment of Sri Lanka in June 2016 for the Havelock City Commercial Development, comprising an Iconic Office Tower and a Shopping Mall built to International Standards at a cost of USD 166 Mn.



Commencement of Phase 3 Construction

The groundbreaking ceremony to commence the construction of Havelock City Phase 3 residential towers was held in June 2016.



Rights Issue

On 23rd of September 2016 the company announced a Rights Issue of 2 Ordinary Shares for every 5 held to raise Rs 7.3 Bn to part finance the Mixed Development Project undertaken by Havelock City (Pvt) Ltd. This was approved by the Shareholders at the EGM on 23rd December 2016 and fully subscribed on 17th January 2017



Product Presentation of NVC

NVC Lighting conducted a product presentation followed by fellowship for its existing and potential stakeholders in November 2016. The event was graced by the NVC Global Marketing Manager who shared valuable insights on NVC Lighting solutions.



Havelock City Commercial Complex – Ground Breaking Ceremony & Inauguration

Havelock City - the premier integrated mixed-use development project in Sri Lanka ceremoniously conducted the Ground Breaking and Inauguration of its Commercial Development under the auspices of Mr. S. P Tao, Chairman in December 2016.



Acquisition of 100% ownership of Mireka Capital Land (Pvt) Ltd (MCL)

The Company acquired the balance 40% shareholding of Mireka Capital Land (Pvt) Ltd from Bank of Ceylon at a cost of Rs 3.88 Bn in December 2016.



Management Review



Property Leasing

Revenue	Profit Before Tax
Rs. 1,886 Mn 2016	Rs. 2,964 Mn 2016
<i>Rs. 1,962 Mn 2015</i>	<i>Rs. 2,890 Mn 2015</i>
Assets	Liabilities
Rs. 33,192 Mn 2016	Rs. 3,347 Mn 2016
<i>Rs. 28,798 Mn 2015</i>	<i>Rs. 1,359 Mn 2015</i>

“The company expects to grow on the positive momentum through a complete building refurbishment and modernization programme, which is in progress to uplift the functionality of building facilities and services, to serve our tenants more efficiently.”



World Trade Center

World Trade Center (WTC) the Iconic Building situated in the heart of the country's commercial hub is one of the most sought after business addresses in Sri Lanka. Even after 20 years, the WTC facility remains unmatched both in terms of built quality, facilities and services.

In spite of the challenging business environment prevalent internationally as well as locally, the average occupancy was 94% for 2016. With the expected stable environment the company is confident in maintaining good occupancy levels in the coming years.

The WTC's standby power generating capacity was upgraded to support all building services excluding air-conditioning. With this upgrade all building services including elevators, escalators, tenant and common area lighting and power, air circulation

and life support systems will be fully functional in the event of a total failure of the natural grid.

The company expects to grow on the positive momentum through a complete building refurbishment and modernization programme, which is in progress to uplift the functionality of building facilities and services, to serve our tenants more efficiently.

During the year the company acquired 100% ownership of SK Investment Lanka (Pvt) Ltd at an investment of Rs 764 Mn which added 17,938 sqft of office space to the leasable area.

The Group's next long term asset with a recurring rental income stream will be the Havelock City Commercial Development, which comprises a landmark 46 storied office tower of 600,000 sqft and a 200,000 sqft shopping mall. A ceremonial

groundbreaking and inauguration was held in December 2016.

Our well experienced and professional team will continue to improve the facilities and services within the building while enhancing tenants experiences to maintain our reputation as the "Best Business Address" in Colombo.

Management Review



Property Trading

Revenue
Rs. 285 Mn 2016
Rs. 974 Mn 2015

Profit Before Tax
Rs. 58 Mn 2016
Rs. 112 Mn 2015

Assets
Rs. 6,551 Mn 2016
Rs. 4,571 Mn 2015

Liabilities
Rs. 2,808 Mn 2016
Rs. 791 Mn 2015

"Phase three comprising two more towers, Stratford and Melford, with 304 luxury apartments is currently under construction and is expected to be completed by mid 2019. Phase 4 which is currently in piling stage will add two more towers with 340 Luxury Apartments and is expected to be completed by mid 2020."



Havelock City

“Truly a city within a City” built on 18 acres of prime land in Colombo, Havelock City is the largest integrated mixed-use development project engineered in Sri Lanka. Comprising of commercial and residential components, it also houses a clubhouse equipped with a range of facilities and a seven acre landscaped elevated garden with lush tropical foliage.

The Havelock City Residential Development is being built in phases, two phases have been completed comprising four apartment towers, namely Park, Elibank, Davidson and Layards where residents enjoy the unique lifestyle Havelock City has to offer. Phase three comprising two more towers, Stratford and Melford, with 304 luxury apartments is currently under construction and is expected

to be completed by mid 2019. Phase 4 which is currently in piling stage will add two more towers with 340 Luxury Apartments and is expected to be completed by mid 2020. Havelock City Residential Phase 3 was launched in March 2016 and as at the year end around 31% of the units have been pre-sold.

The apartments at Havelock City offer all home comforts, elevated to the next level of luxury and elegance. They combine form and function in perfect synthesis, with ingenious space utilization, ample cross ventilation and splendid natural lighting. All apartments are furnished with premium high quality fittings and finishes, carefully curated to suit luxurious and modern urban living.

Anchoring the Havelock City Residence is the Havelock City Commercial Development, comprising a 46 story

office tower offering Grade A premium office space and a shopping mall built to international standards with a fusion of retail, dining and entertainment along with a multiplex cinema.

Upon completion, the Havelock City Commercial Development will add value to the lifestyle offered at Havelock City Residence by complementing living with work spaces, retail experiences and entertainment within hand’s reach.

Havelock City is more than just a residence; it is a community of individuals and families with values and aspirations in common. The complex developed by Mireka Capital Land (Pvt) Ltd. a fully own subsidiary of Overseas Realty (Ceylon) PLC, the owner, manager and developer of the iconic World Trade Center, Colombo.

Management Review



Property Services

Revenue
Rs. 224 Mn 2016
<i>Rs. 167 Mn 2015</i>

Profit Before Tax
Rs. 23 Mn 2016
<i>Rs. 21 Mn 2015</i>

Assets
Rs. 105 Mn 2016
<i>Rs. 58 Mn 2015</i>

Liabilities
Rs. 70 Mn 2016
<i>Rs. 54 Mn 2015</i>

“During 2016 RMS was appointed as the exclusive distributor in Sri Lanka for Faro Barcelona product solutions with a wide range of designer lighting and fans.”



Property Services

Realty Management Services (Pvt) Ltd (RMS) is the leading real estate service provider in Sri Lanka with more than 5.5 Mn sqft of prime commercial and residential properties under its management.

During the last four years, the sector broadened its range of services offered with property management, agency and advisory services on real estate. The company was awarded the facilities management contracts for two more prestigious establishments during 2016.

The rapid development of infrastructure and real estate in Colombo, will create an increased demand for outsourced professional real estate service providers.

Trading

Realty Management Services (Pvt) Ltd (RMS) has been the distributor for NVC Lighting Solutions in Sri Lanka since 2013, NVC Lighting Technology Corporation is the largest lighting manufacturer in China. It offers a broad range of products for professional and domestic use, supported by extensive research, development and manufacturing facilities.

Over the last 3 years NVC has been well accepted by the market and the foundation has been established for accelerated growth.

During 2016 RMS was appointed the exclusive distributor in Sri Lanka for Faro Barcelona product solutions with a wide range of designer lighting and fans.

Financial Review

The Economy

The Sri Lanka economy in 2016 recorded a growth of 4.4% of the Gross Domestic Product (GDP) compared to 4.8% in 2015. The annual average inflation was 4.0% (2015 - 3.8%) and the increase in inflation in latter part of the year was mainly attributed to the impact of tax adjustments and the supply disruptions due to adverse weather conditions. In December 2016 the Average Weighted Prime Lending Rate (AWPLR) increased to 11.52% compared to 7.53% in the previous year while Average Weighted Fixed Deposit Rate (AWFDR) increased to 10.46% compared to 7.57% in the previous year.

During the year the Central Bank decided to allow greater flexibility in determination of the exchange rate opting to strengthen the country's foreign exchange reserves. Consequently, Sri Lanka Rupee depreciated by 3.8% against the US Dollar during 2016, a relatively stable fluctuation compared to the 9% devaluation experienced in 2015.

Within this challenging macro-economic conditions faced by the country in the sphere of growth, inflationary pressures and upward movement on interest rates, the Group recorded a worthy performance for the year under review.

Sri Lanka

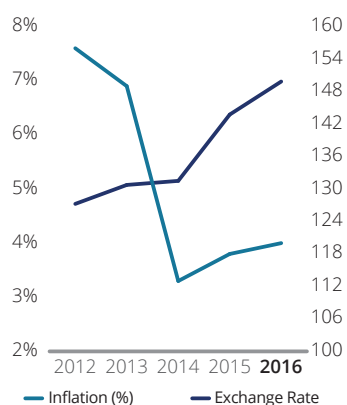

Revenue

During 2016, Group Revenue of Rs 2,431 Mn was 23% lower than last year due to lower revenue recognized from Apartment Sales. The main sources were derived from Overseas Realty (Ceylon) PLC; through leasing of office space at the World Trade Center (WTC) Colombo, Mireka Homes (Pvt) Ltd (MHL); through sale of condominium units at Havelock City (HC) and Realty Management Services (Pvt) Ltd (RMS); through property servicing, agency commission and trading of imported lighting solutions.

The revenue from leasing spaces at WTC marginally decreased by 4% to Rs 1,886 Mn, due mainly to SLFRS adjustment on rental income which resulted in a decrease of Rs 98 Mn of the rent revenue.

Revenue of MHL from the sale of condominium units amounted to Rs 285 Mn, a decrease of 71% over the previous year due to the inability to recognize revenue from Phase 3 Apartment Sales of Havelock City.

RMS contributed Rs 225 Mn (2015 Rs 167 Mn) to the group revenue which included Rs 94 Mn (2015 Rs 81 Mn) from

property services and Rs 17 Mn (2015 Rs 22 Mn) from agency commission and Rs 114 Mn (2015 Rs 64 Mn) from trading of imported lighting solutions.

WTC Colombo

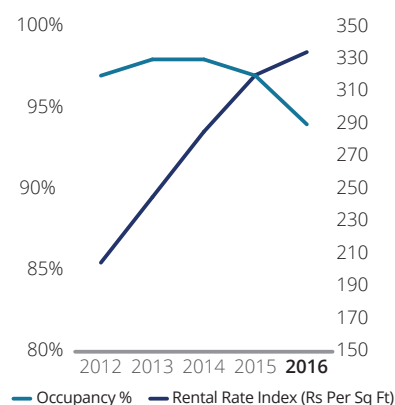

Operating Expenses

The Company's operating expenses for the year of Rs 599 Mn, was only 3% more than last year, with stringent cost control measures adopted by the company.

Group operating expenses including expense incurred on marketing were Rs 1,098 Mn, which was a decrease of 27%, due mainly to lower operating expenses of Mireka Homes (Pvt) Ltd.

Gross Profit

Group Gross Profit of Rs 1,656 Mn was 15% lower than last year. Gross Profit from property leasing of the WTC Colombo was Rs 1,450 Mn, a decrease of 6% over the previous year due mainly to the SLFRS adjustment on the rental revenue. Gross Profit from the sales of apartments at Havelock City was 125 Mn, which was a decrease of 39% over the previous year, due mainly to lower revenue recognized from apartment sales of Havelock City.

Operating profit

The company operating profit (excluding fair value gain) of Rs 1,308 Mn was 8% lower than last year due mainly to SLFRS adjustment made on the rental revenue. Consequently the operating profit margin (excluding fair value gain) decreased to 69% from 71%.

Finance Income and Finance Expenses

Group recorded a Finance income of Rs 332 Mn during the year which was an increase of 83% over the previous year.

For 2016 the company recorded a cost of Rs 43 Mn (2015 – Rs 3 Mn) as fair value adjustment on Rental Deposits, adhering to SLFRS requirements.

Profit Before Tax (PBT)

Group Profit Before Tax for the year of Rs 2,974 Mn was 3% lower than Rs 3,073 Mn of the previous year.

Taxation

The income tax expense of the Group and the Company for 2016 were Rs 44 Mn (2015 – Rs 42 Mn) and Rs 19 Mn (2015 – 23 Mn) respectively.

Cash and Borrowings

The Group's cash and short term investment as at 31st December 2016 were Rs 2,817 Mn (2015 – Rs 4,528 Mn) which was a decrease of 38% over the previous year. This was mainly due to the part financing of the acquisition of the non-controlling interest in Mireka Capital Land (Pvt) Ltd.

The Group's total borrowing was Rs 2,304 Mn (2015 – Rs 96 Mn), which mainly includes Rs 1,949 Mn permanent

overdraft obtained from Bank of Ceylon to partly finance the acquisition of non-controlling interest in Mireka Capital Land (Pvt) Ltd by the Company, Rs 285 Mn loan obtained for funding the HC residential Development by MHL and Rs 46Mn SRCC & Terrorism soft loan obtained from Bank of Ceylon by the Company.

Net Assets

The Group Net Asset value per share as at 31st December 2016 stood at Rs 31.35 (2015 – Rs 32.22).

Earnings per Share

The Group earnings per share for the year 2016 was Rs 3.28 per ordinary share (2015 – Rs 3.44).

Price Earnings Ratio

The Price Earnings ratio of the Company as at 31st December 2016 was 6.1 times (2015 - 6.7 times)

Dividends

Dividend paid to ordinary shareholders in 2015 was Rs 1.50 per share. The Board of Directors has proposed a dividend of Rs 1.25 per share to the ordinary shareholders for the year ended 31st December 2016 on the increased shares. The total Dividend outflow would be Rs 1,554 Mn (2015 Rs 1,265 Mn).

Solvency

Section 56 of the Companies Act no 07 of 2007 requires that a solvency test to be carried out prior to the payment of dividend. A certificate of solvency from the Auditors was obtained for the proposed dividend payment.

Return on Equity (ROE)

The Group Return on Equity (ROE) for the year 2016 was 10% (2015 - 11%) and the decrease was due mainly to lower Sales & Profit from Sale of Apartments.

Assets

The total Group asset base increased from Rs 32,274 Mn in 2015 to Rs 34,181 Mn in 2016. The main increase was from Investment Property which increased by Rs 2,072 Mn with the fair valuation and acquisition of SK Investments Lanka (Pvt) Ltd.

Liability

Total Liabilities as at 31 December 2016 increased to Rs 6,348 Mn compared to Rs 2,157 Mn in the previous year, due mainly to loans obtained during the year and customer deposit received on Apartment sales.

Total Equity

Total Equity decreased by Rs 2,283Mn due to the acquisition of the non-controlling interest in Mireka Capital Land (Pvt) Ltd for a total consideration of Rs 3,880 Mn.

Accounting Policies

The Financial Statements contained in this report are prepared in accordance with the Sri Lanka Financial Reporting Standards (SLFRS) the requirements of the Colombo Stock Exchange and the Companies Act No 07 of 2007.

roof plan

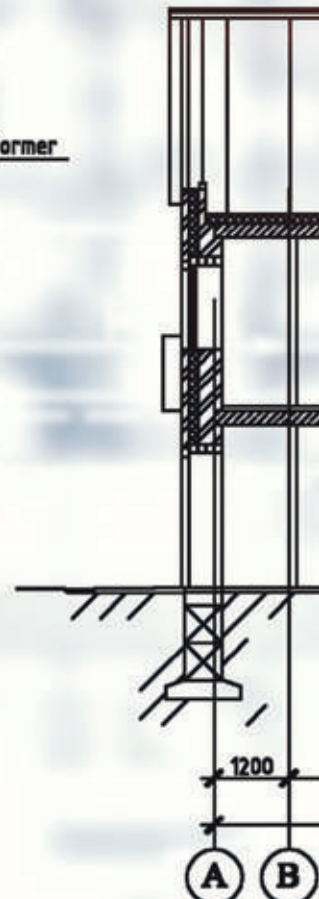
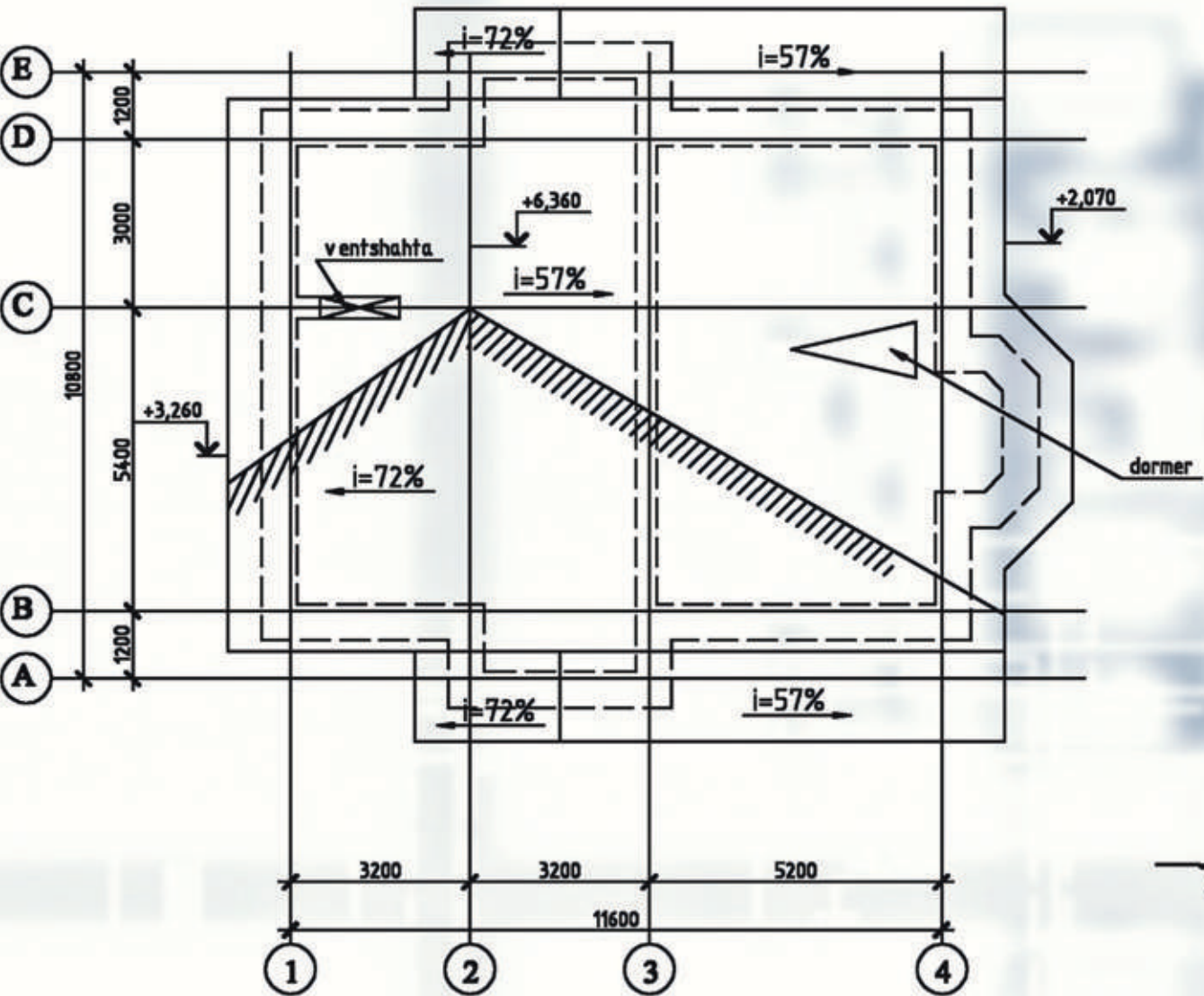

(B)

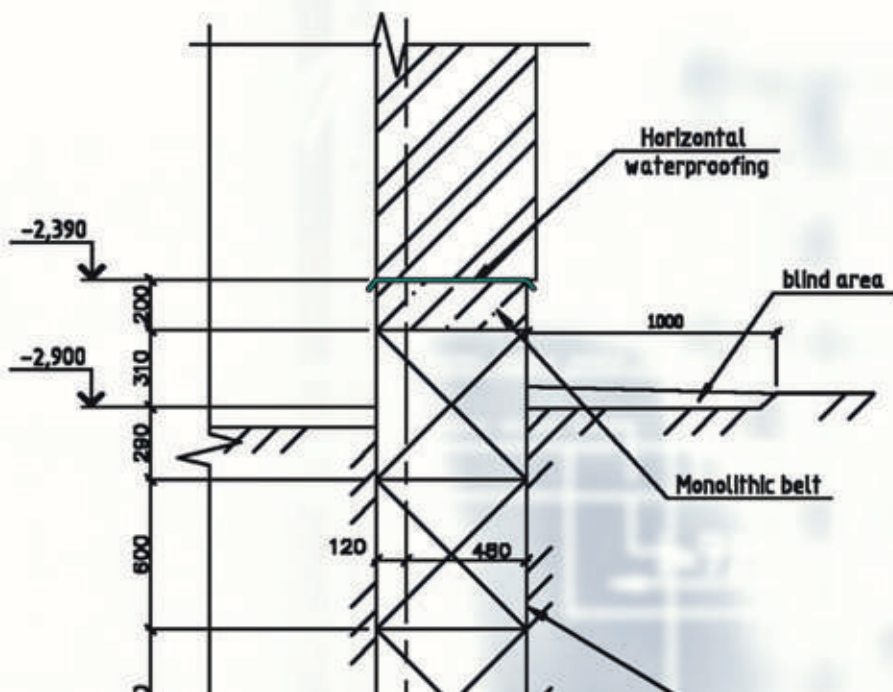

Conventions



Brick



Heater



Sustainability Report

Growing a sustainable business is our core strategy and corporate responsibility has long been a philosophy at Overseas Realty (Ceylon) PLC. It has been a way to connect with the societies in which we operate, a way to positively contribute to the global fight against global warming and most importantly a way to enrich the lives of our stakeholders.

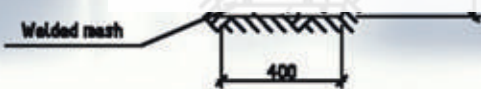

Sustainability Report

Group Sustainability Strategy

Growing a sustainable business is our core strategy and corporate responsibility has long been a philosophy at Overseas Realty (Ceylon) PLC. It has been a way to connect with the societies in which we operate, a way to positively contribute to the global fight against global warming and most importantly a way to enrich the lives of our stakeholders. Our efforts towards that end have primarily been motivated by our need to become more sustainable in all aspects of the business.

Management approach driven by integrated sustainability policy.

The Group continues to strategically integrate sustainable practices across every aspect of its operation. The Group adopts best practices in economic, environmental and social governance in order to give a better life to all the stakeholders and society.

The Management Approach Outlined

Core Area	Management Approach
Risk and Governance	<p>Corporate governance structure, policies and principles</p> <p>Risk Management Framework allows the Board of Directors, the Committee of Management, the Audit Committee and the Senior Management of the Group to play an integral role in the process of risk management.</p>
Market Presence and Economic Value creation	<p>Operates in five key operational areas. Property Leasing, Property Trading, Facility Management, Agency and Trading.</p>
Environmental & Social Sustainability	<p>Environmental and social sustainability policies govern the sustainability efforts and parameters of each of the Company's operational departments.</p> <p>Monitors different key areas such as energy, water usage, recycling water, waste water, solid waste, and quality of air, air pollution, sound pollution, transport, and eco system management, social and cultural development involving internal and external stakeholders.</p>
Employee Development, Equal Opportunity & Anti-corruption	<p>Adopts a human development approach that has yielded positive results especially in terms of career development and inculcation of corporate values and ownership that extends beyond the conventional approach.</p> <p>Adopts a policy of innovative training and continue learning that overcomes the customary barriers to effective learning.</p> <p>Gender equality and equal opportunity governed by Human Resource policy.</p> <p>Anti-corruption training extended to all employees with honesty being key corporate value.</p>
Sustainable Purchase and Produce	<p>Sustainable supplier policy dictates that suppliers be evaluated and preference given based on their own commitments to sustainable practice.</p> <p>Bulk purchasing given priority and supplies in returnable containers of packaging are encouraged.</p>

Water Management

Recognizing the global water challenge, Overseas Realty (Ceylon) PLC is working internally to continuously improve our operations in order to minimize water consumption while reducing water waste in day to day operations. Further we have implemented a rain water harvesting system to harvest rain water, which enables us to use rain water for gardening and fire protection activities. In our Havelock City Project we use internal well water, to maintain large extents of garden.

Biodiversity

Havelock City Project has been designed with a seven acre landscaped roof garden, which ensures the protection of biodiversity through the flora and fauna within the project.



Energy Management

Energy Management Policy

The objective of this policy is to improve energy efficiency, optimize energy consumption, reduce operational cost, maximize return on capital investment, reduce environment and greenhouse gas emissions and conserve natural resources.

The Company is continuously focused to minimize the energy consumption through implementation of various energy conservation methods. Our approach is logical, which contains three main steps.

1. Zero cost implementation
2. Efficient retrofits

3. Replacement with state of the art energy efficient equipment.

The reduction of energy consumption without incurring expenditure is zero cost implementation, where the company employees improve the existing plant and the processes in order to enhance the energy efficiency i.e. rescheduling of operational time of central plant equipment, optimization of common area (AHU) Operations, etc.

Improvements which were done at a cost in order to enhance the efficiency of the plant and the processes are identified as efficient retrofit i.e. electronic ballasts for car park common area lighting, fixed capacitor installation to AHU motors, installation of Variable Speed Drives (VSD) for a high zone chilled water pumps, etc.

Additionally we replaced, high energy consuming chillers, chilled water pumps and condenser water pumps with the objective of reducing energy consumption.

The above practices resulted in the WTC being a true high performance Green Building, with a Gold Certification of Green rating system from Green Building council of Sri Lanka and being awarded the prestigious Gold Flame Award under large scale sector commercial building at Sri Lanka National Energy awards 2014 organized by the Sri Lanka Sustainable energy authority.

Achievements

The Company was awarded the Silver Award for the Land and Property sector at the CA Sri Lanka 52nd Annual Report Awards Ceremony - 2016.



Sustainability Report

Brands

We understand that customers are seeking more than just a transaction experience, they are looking for the validation of Brand Promises and a brand that reflect their own personal value systems. This is the fundamental reason for our offer of two strong brands. Stringent brand guidelines and standards are followed in all external and internal communications and in maintaining consistency in delivery of brand promise.

World Trade Center (WTC) is an internationally recognized reputed brand which has been used by 320 WTC's building located in over 90 countries worldwide. WTC Colombo is synonymous with quality facilities and services. Our other brand 'Havelock City' is also very unique in Sri Lanka, promising a city within a city with its mixed use integrated property development.

Community

The company places high emphasis on contributing to the communities we operate. In order to fulfill this requirement the company has undertaken a series of initiatives aimed at improving the living environment of the communities around its premises. The Group developed and granted the "Sama Vihara" temple to the Buddhist devotees, which is located within the Havelock City.

We conduct annually four evacuation and fire drills at the WTC building in order to safeguard the tenants, visitors, staff and the neighboring buildings and properties.

Our People

Our Human Resources Department is dynamic in recruiting and maintaining a well talented work force; providing a safe and pleasant work environment is essential for a healthy and productive workforce.

Continuous training, development and career progression opportunities are provided to all categories of employees. A structured performance management system is adopted with half yearly reviews, which provides an objective based appraisal system and reward and recognition process.

The company provides medical and surgical insurance policy to cover in house medical treatments to employees and their family. Further, employees are provided personal accident

cover in order to claim the accidental payment and partial disability covering 24 hours of the day. In addition, employee on duty are covered by a workman compensation policy.



The Group's training and development programmers are key policy component of talent retention and ensuring a sustainable competitive advantages. Each year training programs for employees are determined on a need basis, aligning the business specific requirements with gaps identified in employee skills and the competencies. Through the performance appraisal system, employees can request for training when conducting self-appraisals while supervisors also nominate employees for training based on the needs. As part of group career development strategy, the Group carries out Leadership Development, Customer Relationship management, Enhancement of English language proficiency in collaboration with reputed International and local bodies.

The Group places the highest importance on ensuring a safe working environment for all its employees, taking steps to ensure that health and safety concerns are prioritized and address across the Group. All business units within the Group have been empowered to undertake any measure it may deem necessary to ensure that it is a safe place to work, as part of its Human Capital. Accordingly, steps have been taken to improve the cleanliness of the work places. Moreover, sign posts are displayed at all necessary locations to guide the employees and visitors towards desired destinations.

In terms of staff welfare, the key role is played by the Staff Welfare Society which organizes numerous events throughout the year. Few such events are; Annual Trip for the employees and their families at a star class hotel, Sports day, Annual Pirith Ceremony and Annual Get together.



Labor Practices

A fair and sound grievance handling policy and procedure is a pre requisite for good Human Resource practices and for healthy employee - employer relations. This is implemented through the joint consultative committee having employee representatives.

Our grievance practices are aimed at allowing employees to bring to the attention of the management any dissatisfaction or injustice which may exist at the work place. It is a formal process offering employees of different levels solving grievance issues and, aiding to maintain a fair and cordial working environment.

Non discrimination, child labor and compulsory labor

We consider upholding good standards of human rights in our work place and in all our dealings and hence discrimination, child labor and compulsory labor are avoided.

We believe in the fair treatment of employees regardless of their age, race, gender, position or any other diversity factor. Accordingly, our management and employees are expected to adhere to a strict code of ethics in relation to favourism and all forms of discrimination.

Our stance on labor is to employ individuals over 18 years of age at their own free will. Thus no forced or compulsory labor is entertained at our work place. All recruitments are handled centrally at the Human Resources Division ensuring best practices.

Resignation, Termination and Transfers

Our policy and procedure on cessation of services is clearly laid out in our HR Manual. Employees may resign from the company subject to the terms and conditions set in their appointment letters while retirement age of employees would be at the age of 55.

The company may terminate the services of an employee due to reason specified in the manual but should such a situation occur a fair and equitable procedure will be followed.

Compliance with Law and anti corruption

We maintain maximum adherence to all laws applicable within the jurisdiction of Sri Lanka. Our senior management along with the Human Resources Division and Legal Department monitor strict vigilance in this regard.

Risk Management Report

Enterprise Risk Management process

Overview

Risk arises in all our business activities. Risk, in our context, is the component, which has the potential to negatively affect business or an organization. Its' significance is measured in terms of the probability of occurrence. Therefore, it has become a mandatory existence, of an integrated risk management frame work which provides the guide line for managing risks.

Risk Management Framework

A risk cannot be viewed in isolation as it is inter connected and also one aspect might give rise to various other factors. The Overseas Realty Group has a structured risk management process to address different risk categories: Strategic, Operational, Compliance and Financial.

The Board of Directors recognizes that the proper management of risk is a core leadership function that must be practiced throughout the Organization.

Internal Audit process coordinates the identification and documentation of control risk areas throughout the Group,

enhancing the risk management system and monitoring its effectiveness at regular intervals. In addition, during the year-end, the External Auditor issues a Management Letter and informs the Group Management Committee, Audit Committee and the Board of Directors of the outcome of these evaluations. These outcomes are taken into account in the continuing enhancement of our risk management system. Further the Audit Committee constantly evaluates risk, its impact and measures taken to manage risk.

The principal aim of the Group's risk management governance structure and system of Internal Control is to manage business and operational risks, with a view to enhancing the value of shareholders' investments and safeguarding assets.

We have put in place a number of key policies, processes and independent controls to provide assurance to the Board on the integrity of our reporting and effectiveness of our systems of Internal Control and risk management.

The following grid summarizes the main risk areas focused by the Group, its ranking and mitigating strategies.

Risk Type	Rank	Factor	Strategies/ Action Plan
Strategic Risk	Low	Risks of not achieving strategic goals and objectives of the company, and variations etc.	Company operates with a clear Business Plan. Company also operates within an approved Annual Budget & variances are reviewed periodically by the Board of Directors.
Fraud Risk	Low	Risks due to inadequate internal controls, processes and systems. Also due to employee abusing entrusted power for private gains leading to misappropriation of assets.	The Board has approved a structured internal control frame work with different levels of delegated authorization. The company applies an independent internal audit mechanism. Comprehensive policy manual covering all major departments, operations and processes are in place.
Legal and Regulatory Framework	Medium	Risks due to changes to tax and other legal regulations including changes in Government policies.	Constant dialogue and lobbying with Regulatory authorities. Monthly scanning of Government bills. The company has retained the services of Tax Consultants, Legal Consultants & a professional Company Secretary for the respective regulatory requirements.

Risk Management Report

Risk Type	Rank	Factor	Strategies/ Action Plan
Competition	Medium	Risks arising from new Commercial and Residential Developments	Monitoring of existing and new supply of Commercial and Residential Developments. Quarterly competitor Analysis reports.
Construction Costs	Low	Risks from increase in construction material and other costs	Fixed price SLRS contracts are entered into with contractors.
Brand & Reputation	Low	Risks relating to product quality, timely delivery and service standards	Maintaining high product and service quality standards and quality assurance/control systems in project and facilities management. Regular reviews of customer comments and feedback.
Fire	Low	Risks of a fire at the World Trade Center Colombo and Havelock City Residential	Periodic review and maintenance of building fire systems, training of staff on fire protection procedures, conducting regular fire drills, obtaining services of a Professional fire consultant and having adequate insurance cover.
Building-Health and Safety	Low	Risk occurring from threats to personal, staff, tenants and general public at World Trade Center Colombo and Havelock City Residential.	The company complies with all Industrial Safety Requirements. Preventive maintenance programs, potable water quality testing and air quality testing etc. are regularly carried out. Specialized equipment and life support systems maintained by qualified professionals.
Technology Risk	Low	Risks occurring from failure to absorb Technological advancements.	The company has its own engineering maintenance teams abreast with latest technology. Continuous updating & implementation of Energy Efficiency Projects. Participate for Overseas trainings on technical enhancement and changes
Foreign Currency	High	Risks from foreign currency borrowing for the Havelock City Project	Construction contracts are entered into in Sri Lankan Rupees (LKRS). Some apartment sales are contracted in USD. Estimated Currency fluctuation is factored into cost of development. Exchange rate movements are constantly monitored through Cash Flow Forecast.
Interest Rate	Medium	Risks relating to Interest Income and Cost of Borrowings	Monitoring and management of cash flows daily. Negotiating favorable rates and terms on borrowings and deposits. Borrowing at fixed rates.
Credit Recovery	Low	Non recovery of receivables	Regular trade debtor balance review and follow-up. Contractual obligation which allows the company to Adequate refundable deposits are collected from lessees of leased property. Contractual obligation to repudiate a unit whilst retaining 10% of purchase price. Contractual obligation to release assets only upon full payment is made for relevant property.

Corporate Governance Report

Corporate Governance

Corporate Governance at Overseas Realty (Ceylon) PLC encompasses promoting corporate impartiality, transparency and accountability in directing and controlling the company. All structures, principles and policies are focused on ensuring that the company is governed in a manner that safeguards the best interest of all stakeholders and this report aims to provide the details of how this is done in practice.

Company's Brief and Commitment Towards Corporate Governance

We firmly believe that good Corporate Governance is not only the fundamental in ensuring that the company is well managed in the interest of all its stakeholders, but is also essential to attain long term sustainable growth. Corporate Governance is of utmost importance in driving the company towards its high standards of managing the company in an ethical, efficient and effective manner whilst fostering an entrepreneurial culture.

Compliance with Corporate Governance Codes

Overseas Realty (Ceylon) PLC's practices are consistent with the requirements given in the code of best practice on Corporate Governance issued jointly by CA Sri Lanka and the Securities and Exchange Commission of Sri Lanka (SEC) as well as Rule Number 7.10 of Listing Rules issued on Corporate Governance by the Colombo Stock Exchange (CSE). The principles set out in these codes have been adopted by us to shape our corporate governance stance.

Statement of Compliance

Overseas Realty (Ceylon) PLC is fully compliant with the code of Best Practice on corporate governance issued jointly by CA Sri Lanka and SEC. In addition, we have achieved the status of being 'fully compliant' with the applicable section of the listing rules, issued on corporate governance by the SEC. Our status of compliance with each section of the code of best practices on corporate governance issued jointly by CA Sri Lanka and SEC appears on pages 39 to 49. We have also included a table which summarizes the status of compliance with Rule No 7.10 and 7.6 of the listing rules of the CSE, on pages 33 to 38.

Board of Directors

The Company's commitment to uphold highest standards of corporate governance is driven by the Board of Directors which is led by the Chairman, assumes overall responsibility for the governance of the company. Each Director identifies himself/herself with a duty to act in good faith and in the best interest of the Company. The Board is responsible for the shareholders for creating and delivering sustainable shareholder value through management of business activities.

Role of Board of Directors

The fundamental role of the Board is to provide entrepreneurial and coherent leadership within a framework of prudent and efficient controls, which enables risks to be assessed and managed. The Board has the final decision making authority and directs the management team to uphold highest level of integrity, function in compliance within the applicable rules and regulations and delegate the necessary authority to fulfill their job responsibilities. Each Director has unrestricted access to information and services of Senior Management and the Company Secretary. Prior notices are given to the Directors regarding board meetings. The Board papers are circulated well in advance so that all directors could actively deliberate and contribute to the Board proceedings.

Board Composition

The Board portrays a balance between Executive and Non-executive Directors each of whom bring a strong and in-depth mix of knowledge, business skills and experience to the Board's deliberation. By the end of the year there were eleven directors in the Board. Out of them ten directors are non-executive and five of them are considered as independent.

Please refer pages 10 to 13 for profile of the members of the Board of Directors.

Attendance of the Board Meeting

The number of meetings of the Board and individual attendance by members are as follows:

Name	Directorship Status	Meetings Attended/ Meetings Eligible to Attend
Mr. S.P. Tao	Non-Executive	0/4
Mrs. Mildred Tao Ong	Non-Executive	4/4
Mr. Yap Boh Pin	Non-Executive	4/4
Mr. En Ping Ong	Non-Executive	4/4
Mr. H.Z. Cassim	Independent Non-Executive	4/4
Mr. A.M. De S. Jayaratne	Independent Non-Executive	4/4
Mr. L.R. de Lanerolle	Non-Executive	4/4
Mrs. R. Nanayakkara	Independent Non-Executive	4/4
Mr. T.K. Bandaranayake	Independent Non-Executive	3/4
Dr. Raneey Jayamaha	Independent Non-Executive	4/4
Mr. Pravir Samarasinghe	Executive Director	4/4

Re-election

According to the provisions of the Articles of Association of the Company, the Board possesses the power to appoint any person, at any time, as a Director, either to fill a casual vacancy or as an additional member of the Board. Any Director so appointed, shall hold office until the next Annual General Meeting where he/she is then eligible for re-election.

The re-election of a Director safeguards the right of the shareholders by providing a regular reassessment of the composition of the board. The names of the Directors submitted for re-election are provided to the shareholders along with notice of the Annual General Meeting, enabling them to make informed decisions on such appointments.

Directors' Remuneration

Please refer to pages 44 and 45 under Section B for information relation to the remuneration procedure and page 107 for the details on Directors' remuneration.

The disclosures below demonstrate the Company's adherence to Corporate Governance Rules as set out under Section 7.10 and the disclosure in the Annual Report under Section 7.6 of the Listing Rules of the Colombo Stock Exchange.

Rule No.	Corporate Governance Rule	Compliance Status	Details
7.10.1	Non-Executive Directors		
(a)	The Board of Directors of a listed entity shall include at least; <ul style="list-style-type: none"> a. Two Non-Executive Directors; or b. One third of the total number of Directors, whichever is higher should be Non- executive Directors. 	Complied with	As at the conclusion of the immediately preceding AGM all ten (10) out of eleven (11) Directors on the Board functioned in the non- executive capacity.
(b)	The total number of Directors is to be calculated based on the number as at the conclusion of the immediately preceding Annual General Meeting.	Complied with	The total number of directors was eleven (11) as at the conclusion of the immediately preceding AGM.
(c)	Any change occurring to this ratio shall be rectified within ninety (90) days from the date of change.	Not Applicable	

Corporate Governance Report

Rule No.	Corporate Governance Rule	Compliance Status	Details
7.10.2 Independent Directors			
(a)	Where the constitution of the Board of Directors includes only two Non-Executive Directors, both such Non-Executive Directors shall be independent. In all other instances two or one third of non-executive Directors, whichever is higher, shall be 'independent'.	Complied with	As at 31st December 2016 Five (5) out of eleven (11) directors were independent.
(b)	Each Non-executive Director should submit a signed and dated declaration annually of his/ her independence/non-independence in the prescribed format.	Complied with	All Non-Executive Directors have submitted the declaration in the prescribed format.
7.10.3 Disclosure Relating to Directors			
(a)	The Board shall annually make a determination as to the independence or otherwise of the Non-executive Directors and names of Independent Directors should be disclosed in the Annual Report.	Complied with	Please refer note * on page 38 of this Report.
(b)	The basis for the Board to determine a Director is Independent, if criteria specified for independence is not met.	Complied with	Please refer note * on page 38 of this Report.
(c)	A brief resume of each Director should be included in the Annual Report and should include the Director's areas of expertise.	Complied with	Please refer "Profiles of Directors" on pages 10 to 13 of this Report.
(d)	Forthwith provide a brief resume of new Directors appointed to the Board with details specified in 7.10.3(a), (b) and (c) to the rules of the Colombo Stock Exchange.	Not Applicable	
7.10.5 Remuneration Committee			
	A listed entity shall have a Remuneration Committee.	Complied with	Please refer page 50 of this Report.
(a)	The Remuneration Committee Shall comprise of ; a. A minimum of two Independent Non- executive Directors (in instances where an entity has only two directors) or' b. Non-Executive directors, a majority of whom shall be independent.	Complied with	The Committee consists of Five Members, all of whom are Non-Executive Directors, out of whom a majority are independent.
	One Non-Executive Director shall be appointed as Chairman of the Committee by the Board of Directors.	Complied with	The Chairman of the Remuneration Committee is a Non-Executive Director.
(b)	The Remuneration Committee shall recommend the remuneration of the Group Chief Executive Officer and Executive Directors.	Complied with	Please refer Remuneration Committee report on page 50 of this Report which set out the functions of the Committee.

Rule No.	Corporate Governance Rule	Compliance Status	Details
(c)	The Annual Report should set out: a. Names of Directors comprising the Remuneration Committee. b. Statement of remuneration policy. c. Aggregate remuneration paid to Executive & non-executive Directors.	Complied with Complied with Complied with	Please refer Remuneration Committee report on page 50 of this Report.
7.10.6	Audit Committee		
	A listed entity shall have an Audit Committee.	Complied with	Please refer pages 51 and 52 of this Report.
(a)	The Audit Committee Shall comprise of a. A minimum of two independent Non- Executive Directors (in instances where an entity has only two directors) or, b. A majority of Non-executive Directors shall be independent;	Complied with	Audit Committee consists of five Non-executive Directors four of whom are independent.
	One non-executive Director shall be appointed as the Chairman of the Committee by the Board of Directors.	Complied with	Chairman of the Audit Committee is a Non-executive Director.
	Group Chief Executive Officer and Chief Financial Officer should attend Audit Committee Meetings.	Complied with	The Group Chief Executive Officer and the Chief Financial Officer attends the meetings by invitation.
	The Chairman of the Audit Committee or one member should be a member of a recognized professional accounting body.	Complied with	Chairman and Two other members of the Audit Committee are Chartered Accountants with a vast knowledge on Financial reporting and compliance.

Corporate Governance Report

Rule No.	Corporate Governance Rule	Compliance Status	Details
(b)	<p>Functions of the Audit Committee shall include:</p> <p>a. Overseeing of the preparation, presentation and adequacy of disclosures in the Financial Statements in accordance with SLFRS/LKAS.</p> <p>b. Overseeing of the compliance with financial reporting requirements, information requirements of the Companies Act and other relevant financial reporting related regulations and requirements.</p> <p>c. Overseeing the process to ensure that the internal controls and risk management processes are adequate to meet the requirements of the SLFRS/LKAS.</p> <p>d. Assessment of the independence and performance of the external auditors.</p> <p>e. Make recommendations to the Board pertaining to appointment, re-appointment and removal of external auditors, and approve the remuneration and terms of engagement of the external auditors.</p>	<p>Complied with</p> <p>Complied with</p> <p>Complied with</p> <p>Complied with</p> <p>Complied with</p>	<p>Please refer Audit Committee Report on pages 51 and 52 of this Report for the functions of Audit Committee.</p>
(c)	<p>Names of Directors comprising the Audit Committee should be disclosed in the Annual Report.</p> <p>The Audit Committee shall make a determination of the independence of the Auditors and disclose the basis for such determination.</p> <p>The Annual Report shall contain a Report by the Audit Committee, setting out the manner of compliance in relation to the above.</p>	<p>Complied with</p> <p>Complied with</p> <p>Complied with</p>	<p>Please refer the Audit Committee Report on pages 51 and 52 of this Report.</p>
7.6	Disclosure in the Annual Report		
	All listed entities must include in its Annual Reports and accounts, inter alia;		
	a. Names of persons who were directors of the entity during the year.	Complied with	Please refer Corporate Information on inner back cover of this Report.
	b. Principal activities of the entity and its subsidiaries during the year and any changes therein.	Complied with	Please refer page 56 of the Board of Directors Report.
	c. Names and the numbers of shares held by the 20 largest voting and non-voting shareholders and percentages.	Complied with	Please refer page 120 of this Report.

Rule No.	Corporate Governance Rule	Compliance Status	Details
	d. Public Holding percentage.	Complied with	Please refer page 121 of this Report.
	e. A statement of each director's holding and chief executive officer's holdings in shares of the entity at the beginning and end of each year.	Complied with	Please refer page 119 of this Report.
	f. Information relating to material foreseeable risk factors of the entity.	Complied with	Please refer pages 30 to 31 of this Report.
	g. Details of material issues pertaining to employees and industrial relations of the entity.	N/A	No material issues pertaining to employees and industrial relations.
	h. Extents, locations, valuations and other number of buildings of the entity's land holding and investment property.	Complied with	Please refer pages 86 and 122 of this Report.
	i. Number of shares representing the entity' stated capital.	Complied with	Please refer pages 98 and 118 of this Report.
	j. A distribution schedule of the number of holders in each class of equity security and the percentage of their total holdings in the specified categories.	Complied with	Please refer page 118 of this Report.
	k. Following ratios and market price information. 1. Dividend per share 2. Dividend pay out 3. Net asset value per share 4. Market value per share Highest and the lowest value recorded. Value as at the end of the year.	Complied with	Please refer pages 117 to 118 of this Report.
	l. Significant changes in the entity's or its subsidiary's' fixed asset and the market value of land, if the value differs substantially from the book value.	Complied with	Please refer Note 5 to the Financial Statement on page 86 of this Report.

Corporate Governance Report

Rule No.	Corporate Governance Rule	Compliance Status	Details
	<p>EMPLOYEE SHARE OPTION SCHEMES.</p> <p>m. All Following information shall be disclosed in the Annual Report of the listed entity in respect of each ESOS;</p> <ul style="list-style-type: none"> • number of options granted to each category of employees, during the year. • total number of options vested but not exercised by each category of employees during the financial year. • total number of options exercised by each category of employees and the total number of shares arising there from during the financial year. • options cancelled during the financial year and the reasons for such cancellation. • the exercise price. • a declaration by the directors of the entity confirming that the entity or any of its subsidiaries has not directly or indirectly provided funds for ESOS. 	<p>Complied with</p> <p>Complied with</p> <p>Complied with</p> <p>Complied with</p>	<p>Please refer page 57 of the Board of Directors Report.</p>

*Note.

Mr. H.Z Cassim who was appointed as a Non-Executive Director on 12.04.1991, continues to be a Non-Executive, Independent Director of the Company amidst his tenor in office exceeding nine years. Mrs. Rohini L. Nanayakkara was appointed to the Board as a Non-Executive Independent Director on 20.05.2004, continues to be a Non- Executive, Independent Director of the Company amidst her tenor in office exceeding nine years. Mr. Ajit M. De S. Jayaratne was appointed as a Non-Executive Director on 10.10.2005, continues to be a Non-Executive Independent Director of the Company amidst his tenor in office exceeding nine years. Mr. Tissa K. Bandaranayake was appointed as a Non-Executive Independent Director to the Board on 19.05.2011 and Dr. Raneey Jayamaha was appointed as a Non-Executive Independent Director to the Board on 15.03.2013.

Mr. Pravir Samarasinghe was appointed to the Board as an Executive Director on 24.04.2014.

Mr. S. P. Tao, the Chairman of the Company, Mrs. Mildred Tao Ong, Mr. Yap Boh Pin and Mr. En Ping Ong represent the parent Company Shing Kwan Group which hold more than 50% of shares of the Company.

Mr. Ralph De Lanerolle who was appointed to the Board on 03.06.2010 is also an Executive Director of Mireka Capital Land (Private) Limited, which is a subsidiary of the Company.

The Board is of the collective opinion that the majority of Non-Executive Directors are Independent of the management of the company and free from any business or other relationship that could materially interfere in the exercise of their free and fair judgment.

Code of Best Practice of Corporate Governance issued jointly by the Securities and Exchange Commission of Sri Lanka (SEC) and the CA-Sri Lanka.

Section Number		Compliance Status	Company' Commitment
1 The Company			
A Directors			
A.1 The Board	Every public company should be headed by an effective Board, which should direct, lead and control the Company.	Compliant	The Company is headed by an effective Board. The role of the Board and its members, Board functions, Board procedures and governance activities are discussed in detail from pages 32 to 33.
A.1.1 Regular Board Meetings	Frequency of Board meetings. (at least once every quarter)	Compliant	Board meets once every quarter, mainly to review the Company's performance and to determine whether its strategies and business practices are in line with the expectation of the Board. Individual attendance is given on page 33.
A.1.2 Board Responsibilities	Ensure formulation and implementation of a sound business strategy.	Compliant	The Board assumes the primary responsibility for the overall success of the company. The Board is involved in formulating the overall strategy and measuring, that it is implemented by the CEO. The MD/CEO, together with the management team develops corporate strategies, annual budgets and action plans to implement corporate strategies on annual basis. The corporate plan and annual budget are approved by the Board every year and achievement of the objectives set in the plan is monitored closely by the Board.
	Ensure that the MD/CEO and the management team possess the necessary skills, experience and knowledge for effective implementation of the strategy.	Compliant	The Board actively works to ensure that the CEO and the management team continue to have the right balance of skills, experience and knowledge necessary to discharge their responsibilities in accordance with the highest standards of governance.
	Adapt effective CEO and senior management succession strategy.	Compliant	Succession plans are in place for the CEO and for other key managerial positions and are monitored continuously.
	Ensure that effective systems are in place to secure integrity of information, internal controls, business continuity and risk management.	Compliant	Effective systems and procedures are in place to ensure the integrity of information, internal controls and information security. Such systems are continuously monitored by the management, internal and external auditors and at times by independent experts.

Corporate Governance Report

Section Number		Compliance Status	Company' Commitment
A.1.2 Board Responsibilities Contd.	Ensure that the company's activities are conducted in compliance with laws, regulations and ethical standards.	Compliant	The Board has adopted a compliance policy to give direction to the management with regard to compliance activities. The company has also issued a group policy that employees should comply with.
	Ensure that all stakeholder interests are considered in corporate decisions.	Compliant	The board ensures that the interest of all stakeholders is considered and safeguarded in making corporate decision.
	Recognized sustainable business development in corporate strategy, decisions and activities.	Compliant	The Board recognizes the necessity of sustainable business development in the corporate strategy, decisions and activities. Please refer sustainability report on pages 26 to 29.
	Ensure that the Company's values and standards are set with emphasis on adopting appropriate accounting policies and fostering compliance with financial regulations.	Compliant	The company's accounting policies are fully in line with Sri Lanka Accounting Standards (SLFRS/LKAS) which was adopted from the financial year 2013. Further the accounting policies are reviewed annually to be in line with the changing business requirements and best practices in the industry. Please refer independent auditor's report given on page 63.
	Fulfill other Board functions that are vital, given the scale, nature and complexity of the business concerned.	Compliant	The Board takes all its decisions paying due attention to the interest of all stakeholders. The Board also intervenes when necessary, in any other function that is vital given the scale, nature and the complexity of the company's business.
A.1.3 Compliance with Laws and Access to Independent Professional Advice	Act in accordance with the laws of the country and seek professional advice whenever required.	Compliant	The board act in accordance with the laws in the country. The Board has permitted all Directors to seek independent professional advice.
A.1.4 Access to Advice and the Services of a Company Secretary	Advice and Services of the Company Secretary.	Compliant	The company secretary, who is an attorney-at-law by profession, is accessible by any Director for the services of the company. The company secretary advises the board and ensures that matters concerning the Companies Act, board procedures and other applicable rules and regulations are followed. She also serves as the secretary to the audit committee and the remuneration committee.

Section Number		Compliance Status	Company' Commitment	
A.1.5	Independent Judgment of Directors	Bring Independent judgment on various business issues and standards of business conduct.	Compliant	All directors exercise independent judgment on decisions made by the board on issues of strategy, performance, resource allocation and the conduct of business.
A.2	Chairman and Chief Executive Officer	Chairman and CEO are two different positions and need to be divided responsibilities.	Compliant	The functions of the Chairman and CEO are clearly separated to ensure balance of power and authority.
A.2.1		Disclosure required if the positions of the Chairman and the CEO are combined.	Not Applicable	The positions of the Chairman and CEO are separated.
A.3	Chairman's Role	The Chairman's role in preserving good Corporate Governance.	Compliant	The Chairman is responsible for leading the Board and ensuring that it operates under the highest standards of governance.
A.4	Financial Acumen	Availability of sufficient financial acumen and knowledge to offer guidance on matters of finance.	Compliant	The following members of the Board, are knowledgeable and experienced individuals who can provide guidance on matters of finance. All Directors possess qualifications and/or experience in accounting and finance. Mr Yap Boh Pin, Mr Ajith Mahendra De Silva Jayaratne, Mr Tissa Kumara Bandaranayake are qualified Accountants. Please refer profiles of Directors on pages 10 to 13.
A.5	Board Balance	The Board should have a balance of executive and non-Executive Directors.	Compliant	At the end of the year, the Board comprised eleven Directors and all except the CEO, are non-executive, thereby promoting critical review and control. Please refer Page 10 to 13 of the Profile of Directors.
A.5.1		Presence of non- Executive Directors.	Compliant	Ten of the eleven Board members are Non-Executive, which is in excess of one third of the total number of Directors.
A.5.2		Independent Directors.	Compliant	Five Non- Executive Directors are independent, which is in excess of one third of the Non-Executive Directors.
A.5.3		Criteria to evaluate "Independence" of Non-Executive Directors.	Compliant	All five independent non-executive directors meet the criteria for independence as per the code of best practices, corporate governance (code) and listing rules and free of business or other relationships that could moderately influence the exercise of their unfettered and independence judgment.

Corporate Governance Report

Section Number		Compliance Status	Company' Commitment
A.5.4	Annual Declaration of Non-Executive Directors.	Compliant	All Non-Executive directors have submitted the declaration of independence or non-independence as per the code.
A.5.5	Annual determination of 'Independence' of Non-Executive Directors by the Board.	Compliant	The Note on page 38 of this annual report has determined the independence or non-independence of each director.
A.5.6	Appointment and disclosure of senior independent directors.	Not applicable	Since the role of the Chairman and the CEO of the company are separated, this requirement does not arise.
A.5.7	Availability of the senior independent director for confidential discussions with other directors.	Not Applicable	-Do-
A.5.9	Recording of concerns which cannot be unanimously resolved in Board minutes.	Compliant	All decisions of the Board were taken unanimously and there are no concerns raised by the directors during the year which needed to be recorded in the board minutes. However if such concerns do arise the company's policy is to record them accordingly.
A.6	Supply of Information		Financial and non-financial information are analyzed and presented to the board to make accurate decisions.
A.6.1	Managements responsibility to provide the Board with appropriate and timely information.	Compliant	The management ensures that a set of timely accurate relevant and comprehensive information is provided to the Directors before the Board Meeting every quarter, with adequate time for them to review the same and prepare for discussions. All significant financial and non-financial information for the period are included in this analysis.
A.6.2	Adequate time for effective Board Meetings.	Compliant	All Board Papers and papers for subcommittee meetings are circulated at least one week prior to such meetings.
A.7	Appointments to the Board		All new appointments of the Board are made following a formal and transparent procedure.
A.7.3	Disclosure of details of new directors to shareholders.	Compliant	All appointments of new directors are informed to the shareholders with sufficient details via immediate notification to the CSE.

Section Number		Compliance Status	Company' Commitment	
A.8	Re Election	All Directors should be required to submit themselves for re-election at regular intervals and at least once in every three years.	Compliant	Please refer page 38 of the annual report for details of re-election of Directors.
A.8.1		Appointment and re-election of non-Executive Directors.	Compliant	Please refer page 38 of the Annual Report.
A.8.2		Election of Directors by the shareholders.	Compliant	Please refer page 38 of the Annual Report.
A.10	Disclosure of Information of Directors.	Shareholders should be kept advised of relevant details in respect of Directors.		
A.10.1		Disclosures on Directors in the annual report.	Compliant	Required information with respect to Directors are disclosed in this annual report, where relevant. Names, qualifications and profiles, including expertise in relevant functional areas of all Board Members are provided on pages 10 to 13. Details of Directors interest in contracts are given on page 58. Details of related party transactions are provided on pages 106 to 107.
A.11	Appraisal of CEO	The Board should be required, at least annually, to assess the performance of the CEO.	Compliant	Annually the Remuneration Committee and the Board assess the CEO's performance.
A.11.1		Setting annual target for MD/CEO.	Compliant	Based on long term strategy annual objectives are fixed by the Board.
A.11.2		Evaluation of the performance of the CEO.	Compliant	Evaluations of achievement set targets are reviewed annually by the Board.

Corporate Governance Report

Section Number		Compliance Status	Company' Commitment
B.	Directors Remuneration	Companies should establish a formal and transparent procedure for developing policies on executive remuneration and for fixing the remuneration packages of individual Directors. No Director should be involved in deciding his/her own remuneration.	
B.1.1	Presence of a Remuneration Committee.	Compliant	A Remuneration Committee has been appointed and functions within agreed terms of reference. Please refer page 50 for the Remuneration Committee Report.
B.1.2	Composition of Remuneration Committee.	Compliant	Please refer page 50 for details of the composition of Remuneration Committee.
B.1.3	Disclosure of the members of the Remuneration Committee in the Annual Report.	Compliant	Members responsibilities and other information in respect of the remuneration committee are disclosed on page 50.
B.1.4	Determination of remuneration of Non-Executive Directors.	Compliant	Non-Executive Directors who are nominees of the parent company are paid a nominal fee for their attendance at the Board and sub committee meetings.
B.1.5	Ability to consult the chairman and/ or CEO and to seek professional advice by the committee.	Compliant	The committee consults the Chairman and the CEO, where necessary, has access to the professional advice from within and outside the company.
B.2	Level and Makeup of Remuneration	The Levels of remuneration of both Executive and Non-Executive Directors should be sufficient to attract and retain the Directors needed to run the Company successfully.	
B.2.1	Remuneration packages of Executive Directors.	Compliant	The Remuneration Committee and the Board ensure that the CEO who is the only Executive Director on the Board, is provided with an appropriate remuneration package.
B.2.2	Comparison of remuneration with other Companies.	Compliant	The Remuneration Committee compares the remuneration levels of the company with such packages of comparable companies in the industry and is sensitive to changes in the remuneration levels.
B.2.6	Designing performance – based remuneration of Executive Directors.	Compliant	Objectives for the CEO who is the only Executive Director on the Board, are set at the beginning of the year to align his interests with those of the company. Accordingly, his remuneration including the performance bonus is decided based upon the degree of achievement of such pre-set targets.

Section Number		Compliance Status	Company' Commitment
B.2.7 & B.2.8	Compensation commitments on early termination.	Compliant	Termination of the Executive Director (CEO) is governed by his contract of service/employment.
B.2.9	Remuneration of Non-Executive Directors.	Compliant	Non-Executive Directors are paid only on their attendance at meetings.
B.3 Disclosure of Remuneration	The Company's Annual Report should contain a statement of Remuneration policy and details of Remuneration of the Board as whole.		
B.3.1	Disclosure of Remuneration.	Compliant	The aggregate remuneration paid to the CEO and non-Executive Directors is disclosed on page 107 of this report. The Remuneration Committee's Report which highlights the remuneration policy at the Company is give on page 50.
C. Relations with Share Holders			
C.1 Constructive use of the Annual General Meeting (AGM) and Conduct of General Meeting	Boards should use the AGM to communicate with shareholders and should encourage their participation.	Compliant	Please refer page 60 for details of the Annual General Meeting.
C.1.1	Use of Proxy Votes.	Compliant	The Company has in place a mechanism to count all proxy votes to indicate to the chairman the level of proxies lodged on each resolution and the number of votes for and against such resolution.
C.1.2	Separate Resolution to be proposed for each item.	Compliant	The Company proposes separate resolutions on each substantially separate issue. So, shareholders are given the opportunity to vote separately on each substantial issue.
C.1.3	Availability of Chairmen of Board Committees at the AGM.	Compliant	The Chairman of the Board ensures that the Chairman of Board Sub- committees are present at AGM to answer any query by shareholders.

Corporate Governance Report

Section Number		Compliance Status	Company' Commitment
C.1.4	Adequate notice of the AGM.	Compliant	The Annual Report together with notice of meeting and related documents and other resolutions if any is circulated to the shareholders at least 15 working days prior to the date of the AGM. The Annual Report 2015 was submitted to the CSE on 28th March 2016 and was posted to all shareholders by 28th March 2016. The AGM was held on 25th April 2016.
C.1.5	Summary of procedures Governing voting at the General Meeting.	Compliant	The proxy form, which includes a summary of the procedures governing voting at the General Meetings, is circulated to all shareholders.
C.2	The Board should implement effective communication with shareholders.	Compliant	The AGM and the Annual Report are the primary means of communication with shareholders. Additionally, the Company makes disclosures on material and price sensitive matters from time to time to the CSE for dissemination among the public.
C.3	Major and Material Transaction	Compliant	Disclosure of all material transactions including related party transactions.
			Please refer Note 26 to the Financial Statement on page 106 of this Report for the disclosure of the major transaction occurred during the year.
D. Accountability and Audit			
D.1	Financial Reporting		The Board should present a balanced and understandable assessment of the Company's financial position, performance and prospects.
D.1.1	Board responsibility for statutory and regulatory reporting.	Compliant	The Company presents its financial statements in line with Sri Lanka Financial Reporting Standards (SLFRS) and other applicable laws and regulations.
D.1.2	Declarations by Directors in the Directors' report.	Compliant	The Directors have made all required declarations in the Annual Report of the Board of Directors on the affairs of the company which is given on pages 56 to 60.
D.1.3	Statements by Directors and Auditors on responsibility for financial reporting.	Compliant	Page ... contains the statement setting out the responsibility of the Board for the preparation and presentation of Financial Statements.
D.1.4	Management Discussion Analysis.	Compliant	The Management discussion and analysis are appearing in pages 16 to 23.

Section Number		Compliance Status	Company' Commitment
D.1.5	Declaration by the Board on the going concern of the business.	Compliant	The Board after conducting necessary reviews and enquires decided to apply the 'going concern' assumption in preparing the company's Financial Statements for the year 2016. The declaration of the company as a 'going concern' is given in the Directors Report on page 60.
D.1.6	Requirement to summon an Extraordinary General Meeting (EGM) to notify serious loss of capital.	Not applicable	
D.2	Internal Controls.	Compliant	The Board maintains a sound system of internal controls to safeguard shareholders' investments and the Company assets.
D.2.1	Directors to conduct an annual review of internal controls.	Compliant	The Board has overall responsibility for the system of internal controls and has delegated some of these responsibilities to the Audit Committee.
D.2.2	The need for an internal audit function.	Compliant	The Company has appointed Ms Pricewaterhouse Coopers (PWC) as the Internal Auditors of the Company. All reports by the Internal Auditors are tabled at the Audit Committee meetings.
D.3	Audit Committee.	Compliant	The Board has established formal and transparent arrangement for considering how they should select and apply accounting policies, financial reporting and internal control principles and maintain an appropriate relationship with the company auditors.
D.3.1	Duties of the Audit Committee.	Compliant	The Audit Committee monitors and reviews the External Auditors independence, objectivity and the effectiveness of the audit process, taking into account the relevant professional and regulatory requirements.

Corporate Governance Report

Section Number		Compliance Status	Company' Commitment
D.3.3	Terms of reference of the Audit Committee.	Compliant	The Audit Committee operates with clearly defined terms of reference which are reviewed annually.
D.3.4	Disclosure of names of the members of the Audit Committee.	Compliant	Names of Directors comprising the Audit Committee are set out on page 51 of the Annual Report.
D.4	Code of Business Conduct & Ethics.	Compliant	Companies must adopt a Code of Business Conduct and Ethics for Directors and Members of the Senior Management team and must promptly disclose any waivers of the code by Directors or others.
D.5	Corporate Governance Disclosure.	Compliant	Directors should be required to disclose the extent to which the Company addresses to establish principles and practices of good corporate governance.
D.5.1	Disclosure of compliance with the Corporate Governance Code.	Compliant	Page 39 to 48 set out the manner and extent to which the company has complied with the principles and provisions of the Code of Best Practice on Corporate Governance issued jointly by the SEC and the CA Sri Lanka.

Section Number	Compliance Status	Company' Commitment
2. Shareholders		
E. Institutional Investors		
E.1 Shareholder Voting	Should ensure institutional shareholders' voting intentions are translated into practice.	
E.2 Evaluation on Governance Disclosures	Institutional investors should be encouraged to give due weight to the relevant governance arrangements.	
F. Other Investors		
F.1 Investing/ Divesting Decisions	Individual Shareholders are encouraged to seek independent advice on investing or divesting decisions.	
F.2 Shareholder Voting	All Shareholders are encouraged to participate at Annual General Meeting and cast their votes.	
G. Sustainability Reporting		
G.1.1 - G.1.7	Disclose the policies and procedures adopted to develop a sustainable business.	Compliant Refer Sustainability Report on pages 26 to 29.

Remuneration Committee Report

Composition of the Committee

The Remuneration Committee consists of five members out of whom four are Non-Executive Independent Directors. The Remuneration Committee consists of the following members;

Mr. H. Z. Cassim	- Independent Non-Executive Director (Chairman of the Committee)
Ms. Rohini L. Nanayakkara	- Independent Non-Executive Director
Mr. Ajit M.de S. Jayaratne	- Independent Non-Executive Director
Mr. Tissa K. Bandaranayake	- Independent Non-Executive Director
Mr. En Ping Ong	- Non Executive Director

The brief profiles of the directors are given on pages 10 to 13 of the Annual Report.

Scope of the Committee

The Committee deliberates and recommends to the Board of Directors on remuneration packages, annual increments and bonuses paid to the Chief Executive Officer and other senior level staff. The Committee is also responsible for the determination of the compensation of the Executive Directors and fees paid to the Non-Executive Directors for participation at Board meetings.

Remuneration Policy

The Company's remuneration policy aims to attract and retain qualified and experienced team of high caliber managers and professionals and reward their performance.

Remuneration policy of the Company with regard to increments and bonus schemes is based on the performance management system and evaluation systems installed by the Company. Once the remuneration policy of the Company, as recommended by the Committee is approved by the Board, the Remuneration Committee will then approve and recommend to the Board, the finalised proposals for the granting of increments to the key senior level staff.

The Remuneration Committee take into account the performance of the Company and long term shareholder returns, in all their deliberations.

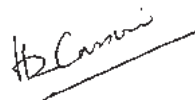

H. Z. Cassim

Chairman - Remuneration Committee

09th February 2017

Audit Committee Report

The Audit Committee of the Overseas Realty (Ceylon) PLC, appointed by and responsible to the Board of Directors, comprises four Independent Non-Executive Directors and a Non-Executive Director as follows:

Mr. Ajit M de S. Jayaratne	– Independent Non-Executive Director (Chairman of the Committee)
Mr. H.Z. Cassim	– Independent Non-Executive Director
Mr. Yap Boh Pin	– Non-Executive Director
Mrs. Rohini Nanayakkara	– Independent Non-Executive Director
Mr. Tissa K Bandaranayake	– Independent Non-Executive Director

The Chairman of the Committee Mr. Ajit M de S. Jayaratne, an independent non-executive Director, is a finance professional with over 25 years of post qualification experience. He is a Fellow member of the Institute of Chartered Accountants of Sri Lanka and the Institute of Chartered Accountants of U.K.

A Charter was approved and adopted by the Board in February 2012 to formalise the Committee's responsibilities in exercising its oversight role in the areas of financial reporting, internal controls, risk management and regulatory/statutory compliance.

The members have a well-balanced blend of experience in the commercial sectors, financial sectors and audit sectors, real estate and real estate development sectors and have displayed high standards of integrity and business acumen. These attributes and the wealth of experience and exposure they bring in, contribute to the effectiveness in which the Committee carries out its duties.

The profiles of the members which detail their background and professional experience are on pages 10 to 13 of this Report.

Role of the Audit Committee

The Audit Committee's main objective is to assist and represent the Board of Directors in discharging its responsibilities by overseeing the financial reporting process to ensure balance, transparency and integrity of published financial information, oversee the internal and external audit process, review the effectiveness and adequacy of the internal control and risk

management process, assessing the performance of the internal and external auditors, ensuring independence and ensuring compliance with laws and regulations which effect financial reporting and business conduct. In fulfilling this role, the Audit Committee is empowered to examine the financial records of the Company, internal auditor's reports and other communications as necessary in order to ensure the Company adheres to accepted norms of ethical guidelines, rules and regulations.

The Audit Committee recommends the appointment of external auditors ensuring their independence and maintains a close professional relationship with them. The Committee also recommends the fees payable to them in the execution of these services.

Meetings

The Audit Committee has met four (04) times during the year ended 31 December 2016 and the attendance was as follows:

Mr. Ajit M de S. Jayaratne – Chairman	4/4
Mr. H.Z. Cassim	4/4
Mr. Yap Boh Pin	4/4
Mrs. Rohini L Nanayakkara	4/4
Mr. Tissa K Bandaranayake	3/4

The Company Secretary functions as the Secretary to the Audit Committee. Meetings were attended by the Group Chief Executive Officer and Group Chief Financial Officer and other senior management members by invitation. The proceedings of the Audit Committee are regularly reported to the Board.

Internal Audit

The internal audit function is outsourced to PricewaterhouseCoopers (PWC) for all companies in the Group as recommended by the Audit Committee. The observations of the internal auditors are tabled at the Audit Committee and the Committee invites representatives of PWC to discuss observations and recommendations made in their reports. Follow up and implementation of previous internal audit recommendations are also discussed and reviewed by the Committee with PWC representatives. The Committee appraises the Board on the status and adequacy of internal controls and the effectiveness there of.

Audit Committee Report

The Committee is of the view that adequate controls, processes and procedures are in place to provide reasonable assurance to the Board, that the Company's assets are safeguarded and adequate financial reporting systems are in place. The internal auditor's reports are made available to external auditors as well.

Property Valuation

An independent Chartered Valuation Surveyor Mr. P B Kalugalagedara has conducted the annual valuation of the Investment Property of the Group. The Committee has discussed and understood the valuation method and the assumptions used in the determination of the fair value of Investment Property.

External Audit

The Company has appointed Ernst & Young as its external auditor and the services provided by them are segregated between audit/assurance services and other advisory services such as tax consultancy. The Audit Committee reviews these audit and non-audit functions of the External Auditors before such services are assigned in order to ensure that the provisions of such services does not impair independence and that work is assigned in such a manner as to prevent any conflict of interest.

The Audit Committee has reviewed and discussed the key observations and recommendations on the Management Letter issued by Ernst & Young in the presence of their representatives.

Ernst & Young has also issued a declaration as required by the Companies Act No. 7 of 2007, that they do not have any relationship or interest in any of the companies in the Group, which may have a bearing on the independence of their role as auditors.

The Committee has recommended the re-appointment of Messrs. Ernst & Young as Auditors for the financial year ending 31 December 2017, at a fee to be determined by the Board of Directors, subject to the approval by the shareholders at the Annual General Meeting.

Conclusion

The Committee is satisfied that the Company's internal controls are effectively implemented as designed, and that the Company's assets are adequately safeguarded. The Company's Internal and External Auditors have been effective and independent throughout the year.

The Committee is also satisfied that the operational controls and the application of appropriate accounting policies provide reasonable assurance that the financial statements of the Company are true and fair.

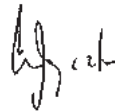

Ajit M. de S. Jayaratne

Chairman - Audit Committee

09th February 2017

Related Party Transactions Review Committee Report

Introduction

The Related Party Transactions Review Committee was formed by the Board as a Board Committee. The role of the Committee is to provide independent review, and oversight of all related party transactions on behalf of the Board in compliance with the provisions contained in section 9 of Colombo Stock Exchange listing rules.

Composition of the Committee

The Related Party Transaction Review Committee of ORCL is appointed by the Board of Directors and the present Committee comprises of four (4) Independent Non-Executive Directors and one (1) Non-Executive Director of the Board. The composition of the Committee fulfilled the requirements of the Listing Rule No. 9.2.2 of the Colombo Stock Exchange, throughout the financial year.

Members of the Related Party Transaction Review Committee are as follows:

Mr. Ajit M de S. Jayaratne	– Independent Non-Executive Director (Chairman of the Committee)
Mr. H.Z. Cassim	– Independent Non-Executive Director
Mrs. Rohini Nanayakkara	– Independent Non-Executive Director
Mr. Tissa K. Bandaranayake	– Independent Non-Executive Director
Mr. Yap Boh Pin	– Non-Executive Director

Policies and Procedures

The members of the Board of Directors of the Company have been identified as Key Management Personnel. In accordance with the Related Party Transaction Policy, the declarations are obtained from all Key Management Personnel of the Company for the purpose of identifying parties related to them. Based on the information furnished in these declarations, the Company retrieves data on related party transactions from the data base of the Company.

The mandate of the committee includes inter-alia followings:

- Review in advance all proposed Related Party Transactions of the Company.
- Update the Board of Directors on the Related Party Transactions of the company on a quarterly basis.

- Review all related party transactions in line with the regulatory requirements.
- Make immediate market disclosure on any applicable related party transactions as required under Section 9 of the Listing Requirements of the Colombo Stock Exchange.
- Make appropriate disclosures in the annual report on related party transactions as per the regulatory guidelines.

Meetings and Attendance

The Committee met on four occasions during the financial year 2016 and the members' attendance record is given below.

Mr. Ajit M de S. Jayaratne – Chairman	4/4
Mr. H.Z. Cassim	4/4
Mr. Yap Boh Pin	4/4
Mrs. Rohini Nanayakkara	4/4
Mr. Tissa K Bandaranayake	3/4

In addition to the Committee members, the meeting was attended by the Group CEO and Group CFO on invitation. The Company Secretary was also present at the meeting.

Related Party Transactions during the Year

The activities and observations of the Committee are communicated to the Board. Details of related party transactions entered into by the Company during the year are disclosed in Note 26 to the Financial Statements.

Declaration

A declaration by the Board of Directors in the Annual Report as a negative statement to the effect that no related party transaction falling within the ambit of the Listing Rules was entered into by the Company during the year, is given in the Annual Report of the Board of Directors on page 59.

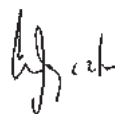

Mr. Ajit M. de S. Jayaratne

Chairman – Related Party Transaction Review Committee

09th February 2017

Financial Report

Annual Report of the Board of Directors | 56
 Directors, Statement on Internal Controls | 61
 Directors' Responsibility for Financial Reporting | 62
 Independent Auditors' Report | 63
 Statement of Financial Position | 64
 Statement of Profit or Loss | 65
 Statement of Comprehensive Income | 66
 Statement of Changes in Equity | 67
 Statement of Cash Flows | 68
 Notes to the Financial Statements | 69
 Group Performance - Ten Year Summary | 116

FINANCIAL CALENDER		
Interim Financial Statements	Target set for 2017	Achievement in 2016
1st Quarter (Ended 31st March)	April 2017	26th April 2016
2nd Quarter (Ended 30th June)	July 2017	28th July 2016
3rd Quarter (Ended 30th September)	October 2017	20th October 2016
4th Quarter (Ended 31st December)	January 2018	06th January 2017
Annual Report and financial Statements to shareholders		
2015		28th March 2016
2016	March 2017	
Dividends		
First and Final dividend for 2015		26th April 2016
First and Final dividend for 2016	25th April 2017	
Annual General Meetings		
34th Annual General Meeting		25th April 2016
35th Annual General Meeting	24th April 2017	



Annual Report of the Board of Directors

General

The Board of Directors has pleasure in presenting their report on the affairs of the Company together with the audited Financial Statements of Overseas Realty (Ceylon) PLC and the audited Consolidated Financial Statements of the Group for the year ended 31st December 2016. The details set out herein provide the pertinent information required under Section 168 of the Companies Act No. 07 of 2007, the Colombo Stock Exchange Listing Rules and the recommended best practices on Corporate Governance.

Overseas Realty (Ceylon) PLC is a Public Listed Company with limited liability, incorporated in Sri Lanka on 28th October, 1980 and re-registered under the Companies Act No.07 of 2007.

Principal Activities

The principal activities of the Company during the year continued to be property leasing, property trading, and provision of property services. There were no significant changes in the nature of principal activities of the Company and its subsidiaries during the financial year under review.

Mireka Capital Land (Pvt) Ltd is a subsidiary of the Company which has undertaken the development of the "Havelock City" Project and providing infrastructure facilities to the project. The development of residential apartments is undertaken by Mireka Homes (Pvt) Ltd, a fully owned subsidiary of Mireka Capital Land (Pvt) Ltd. Havelock City (Pvt) Ltd has undertaken the development of the Commercial component of the "Havelock City" project. Realty Management Services (Pvt) Ltd provides property services, and trading of lighting solutions.

Review of Business

A review of financial and operational performance of the Company and its subsidiaries during the year, and the future developments of the Company is contained in the Financial Review (Pages 22 to 23) and Management Review of Operations (pages 16 to 21) of this Annual Report. The Audited Financial Statements are given on pages 63 to 115 of the Annual Report. These reports together reflect the state of affairs of the Company and its subsidiaries during the period under review.

Financial Statements

The Financial Statements of the Company and the Group are given on pages 64 to 115.

Auditors' Report

The Auditors' Report on the Financial Statements of the Company and the Group is given on page 63.

Accounting Policies

The Significant accounting policies adopted in the preparation of the Financial Statements are given on pages 69 to 83.

The financial statements of the Company have been prepared in accordance with Sri Lanka Accounting Standards (SLFRS/ LKAS) as issued by CA Sri Lanka.

Group Turnover

The turnover of the Group during the year under review was Rs. 2,430,733,019/- (2015 - Rs. 3,140,666,111). A detailed analysis of the Group's turnover, profits and asset allocation relating to the different segments of the business is given in Note 3 to the Financial Statements.

Financial Results and Dividend

The Group recorded a consolidated net profit of Rs. 2,930,117,501/- (2015 - Rs. 3,030,853,427/-) for the year. The Consolidated Income Statement along with the Company's Income Statement for the year is given on page 65.

The Directors recommended the payment of a first and final dividend of Rs. 1.50 per share for the financial year ended 31st December 2015 which was approved by the shareholders at the Annual General Meeting of the Company held on 25th April 2016.

The dividend was paid out of tax free profits, as exempt from tax in terms of the BOI concessions granted to the Company.

At the meeting of the Board of Directors held on 09th February 2017, the Directors recommended the payment of a first and final dividend of Rs 1.25 per ordinary share for the financial year ended 31st December 2016 to be approved by the Shareholder at the Annual General Meeting of the Company to be held on 24th April 2017.

Directors have confirmed that the Company satisfied the Solvency test requirement under section 56 of the Companies Act No. 07 of 2007 and the solvency report was obtained from the auditors.

Property, Plant & Equipment

Capital expenditure during the year, on property plant & equipment by the Group and by the Company incurred amounted to Rs. 80,615,134/- (2015 - Rs. 35,939,895/-) and Rs. 3,852,381/- (2015 - Rs. 16,557,912/-) respectively. The carrying value of the Property, Plant and Equipment of the Group and the Company as at the reporting date amounted to Rs. 1,782,027,248/- (2015 - Rs. 1,598,105,407/-) and Rs. 391,285,879 (2015 - Rs. 363,934,865/-) respectively.

An analysis of the property plant & equipment of the Company, additions and disposals made, together with the depreciation charge for the year, is set out in Note 6 to the Financial Statements on page 88.

Market Value of the Building

All the buildings owned by the Group were subjected to a revaluation by an independent qualified valuer. The carrying value of the building of the Group is Rs. 1,092,453,614 (2015 - Rs. 1,062,741,472). The details are provided in Note 6.1.3 to the Financial Statements.

Fair Value of Investment Properties

The fair value of Investment properties owned by the Group as at 31st December 2016 is included in the Financial Statements at Rs. 24,651,770,855/- (2015 - Rs. 22,579,410,997/-) based on the Independent valuations undertaken by the Chartered Valuation Surveyer in December 2016. The Directors are of the opinion that the value is not in excess of the current market value. The details are provided in Note 5 to the Financial Statements.

Investments

The details of investments held by the Company are disclosed in Note 8 on page 93 of the Financial Statements.

Stated Capital and Reserves

The total stated capital of the Company amounts to Rs. 11,162,751,513/- (2015 - Rs. 11,162,751,513/-) comprising No of Shares 887,878,273/- (2015 - 887,878,273/-), as given in note 13 to the Financial Statements.

Total Group Reserves as at 31st December 2016 was Rs. 16,670,698,120/- (2015 - Rs. 17,442,243,185/-). The movement of these reserves is shown in the Statement of Changes in Equity in the Financial Statements on page 67.

Employee Share Option Scheme

At the Extraordinary General Meeting of the Company held on 24th May 2012 the establishment and implementation of an employee share option plan ("ESOP") to issue to the executive directors and executives employed by the Company and its subsidiaries, as may be decided by the Board was approved. ESOP which will entitle such employees and Executive Directors to subscribe to and purchase shares offered by the Company totaling to 25,305,530 amounting to 3% of the issued shares in the Company ("the Options") at an exercise price being the market price of the shares of the Company at the time of granting of the Option or the volume weighted average price of the shares of the Company thirty (30) days prior to the grant of the Option whichever is higher, was approved at the EGM held on 24th May 2012.

The Option was not granted to any category of employees of the Company during the financial year under review.

Board of Directors

The Board of Directors of the Company consists of eleven Directors as at the end of the financial year and their profiles are on pages 10 to 13.

The basis on which Directors are classified as independent Non-Executive Directors is discussed in the Corporate Governance Report.

Dr. Raneey Jayamaha retires by rotation in terms of Article 29 of the Article of Association of the company, and being eligible has offered herself for re-election.

The proposed resolutions proposes that the age limit of 70 years referred to in Section 210 of the Companies Act No. 07 of 2007 shall not apply to Mr. Shing Pee Tao who attained the age of 70 years on 25th December 1986, Mr. Hussain Zubire Cassim who attained the age of 70 years on 9th September 1995, Mrs. Rohini Letitia Nanayakkara, who attained the age of 70 years on 12th April 2006, Mr. Ajit Mahendrs De Silva Jayaratne, who attained the age of 70 years on 30th April 2010, Mr. Yap Boh Pin, who attained the age of 70 years on 2nd February 2011, Mr. Tissa Kumara Bandaranayake, who attained the age of 70 years on 3rd January 2013, Mr. Leslei Ralph De Lanerolle, who attained the age of 70 years on 5th January 2013 and that they be re-elected as a Director of the Company.

Annual Report of the Board of Directors

Board Sub Committees

The Board of Directors of the Company has formed the following sub committees and following members serve on the Board Sub Committees. Details of Board Sub- Committee meetings (Remuneration Committee, Audit Committee and Related Party Transactions Review Committee) are presented on pages 50 - 53.

Audit Committee

Ajit Mahendra De Silva Jayaratne (Chairman)
Hussein Zubire Cassim
Yap Boh Pin
Rohini Letitia Nanayakkara
Tissa Kumara Bandaranayake

Remuneration Committee

Hussein Zubire Cassim (Chairman)
Ajit Mahendra De Silva Jayaratne
Rohini Letitia Nanayakkara
En Ping Ong
Tissa Kumara Bandaranayake

Related Party Transactions Review Committee

Ajit Mahendra De Silva Jayaratne (Chairman)
Hussein Zubire Cassim
Yap Boh Pin
Rohini Letitia Nanayakkara
Tissa Kumara Bandaranayake

Interest Register

The Company maintains an Interest Register as per the Companies Act No. 07 of 2007. The Directors of the Company have duly declared the information as provided for in section 192 (2) of the Companies Act No. 07 of 2007 and the declarations made were tabled for the information of the Directors and the entries in the Interest Register were made and/or updated accordingly. The Interest Register is kept at the registered office of the Company.

Directors' Interest in Shares

The Shareholdings of the Directors of the Company at the beginning and at the end of the year was as follows:

Name of Director	31st December 2015		31st December 2016	
	Direct Interest	Deemed Interest	Direct Interest	Deemed Interest
Mr S P Tao	Nil	732,335,424*	Nil	732,335,424*
Mrs Mildred Tao Ong	Nil	500,384,334*	Nil	516,584,334*
Mr Yap Boh Pin	Nil	500,384,334*	Nil	516,584,334*
Mr En Ping Ong	400,000	Nil	400,000	Nil
Mr H Z Cassim	Nil	Nil	Nil	Nil
Mr A M De S Jayaratne	Nil	Nil	Nil	Nil
Mr L R de Lanerolle	Nil	Nil	Nil	Nil
Mrs R Nanayakkara	Nil	Nil	Nil	Nil
Mr T K Bandaranayake	Nil	Nil	Nil	Nil
Dr Ranees Jayamaha	Nil	Nil	Nil	Nil
Mr Pravir Samarasinghe	Nil	Nil	Nil	Nil

*The deemed interests in shares as declared by Mr. S P Tao is as a director of Shing Kwan Group excluding Shing Kwan (Pte) Ltd and as a shareholder of Unity Builders Limited, Mrs. Mildred Tao Ong as a director/ shareholder of the Shing Kwan Group and a director of Unity Builders Limited and Mr. Yap Boh Pin's deemed interest is declared as the spouse of a director of the said Shing Kwan Group including Unity Builders Limited.

Related Party Transactions

There are no related party transactions which exceed the threshold of 10 percent of the equity or 5 percent of the total assets, whichever is lower in relation to non-recurrent related party transactions or 10 percent of the gross revenue in relation to recurrent related party transactions. The Company has complied with the requirements of the Listing Rules of the Colombo Stock Exchange on Related Party Transactions.

The Directors have disclosed transactions, if any, that could be classified as Related Party Transactions in terms of LKAS 24 - 'Related Party Disclosures', and are given in Note 26 to the Financial Statements.

Directors' Interest in Transactions

The Directors of the Company have made a general disclosure in terms of section 192(2) of the Companies Act No. 07 of 2007. The particulars of those transactions are set out on pages 106 to 107 of the Annual Report.

Directors' Remuneration

Directors' remuneration, in respect of the Company and the Group for the financial year ended 31st December 2016 is given in the Note 26 to the Financial Statements, on page 107.

Donations

Donations made by the Group amounted to Rs. 60,500/- (2015 - Rs. 3,009,000/-) which includes a sum of Nil (2015 Rs. 3,000,000/-) made to Government approved charities.

Directorship held in Other Entities

Directors have made a general disclosure of their directorships and positions held in other entities and the Interest Register has been accordingly updated.

Insurance and Indemnity

The Company has obtained an indemnity and insurance policy from Allianz Insurance Lanka Limited for its Directors and Officers amounting to US\$ 1 Million for the period covering 1st January to 31st December 2016.

Internal Controls

The Board ensures that there is an effective and comprehensive process for identifying, evaluating and managing any significant risks faced by the Company, compliance controls

and risk management to safeguard the assets. The Board places emphasis in assuring proper accounting records are maintained and the reliability of financial information. The Audit Committee of the Company receives the reports of the internal audit reviews, monitors the effectiveness of internal control systems of the Company and makes periodical recommendations to the Board.

The Directors' Statement on Internal Controls on page 61 gives further details.

Corporate Governance

The Board places emphasis in instituting and maintaining good governance practices and principles. Therefore the management and operation of the Company and its subsidiaries are effectively directed and controlled within the Corporate Governance framework as set out in pages 32 to 49 in this Report.

Shareholdings

There were 3,917 (2015 - 4,361) registered shareholders of ordinary shares as at 31st December 2016. The distribution of shareholdings is given on page 118 of this Report.

Shareholder Information

Information relating to earnings, dividends, net assets, market value per share and share trading is given on pages 117 and 119 in the Financial Review section of this Report.

Major Shareholders

The twenty largest shareholders of the Company as at 31st December 2016 together with an analysis of the shareholdings are given on page 120 of this Report.

Directors' Responsibility for Financial Reporting

The Directors are responsible for the preparation of Financial Statements of the Company to reflect a true and fair view of the state of affairs of the Company. The Directors are of the view that these Financial Statements have been prepared in conformity with the requirements of the Sri Lanka Accounting Standards (SLFRS/LKAS), Sri Lanka Accounting and Auditing Standards Act No 15 of 1995, Companies Act No 07 of 2007, Inland Revenue Act No. 10 of 2006 and amendments thereto, and the Listing Rules of the Colombo Stock Exchange. The Statement of Directors' Responsibility for Financial Reporting is given on page 62 and forms an integral part of this report.

Annual Report of the Board of Directors

Compliance with Laws and Regulations

The Directors, to the best of their knowledge and belief, confirm that the Company has not engaged in any activities contravening the Laws and Regulations of the country.

Statutory Payments

The Directors to the best of their knowledge and belief are satisfied that all statutory payments due to the government and in relation to the employees have been made in full and on time.

Events after Statement of Financial Position Date

There have not been any material events that have occurred subsequent to the date of the Statement of Financial Position that require adjustments to the Financial Statements, other than those disclosed in Note 30 to the Financial Statements.

Going Concern

The Board of Directors is satisfied that the Company and its subsidiaries have adequate resources to continue its operations in the foreseeable future. Accordingly, the Financial Statements are prepared on the going concern concept.

Auditors

The Audit Committee reviews the appointment of the Auditors, their effectiveness, independence and relationship with the Company and its Group. In accordance with the Companies Act No. 7 of 2007, a resolution proposing the re-appointment of Messrs Ernst & Young, Chartered Accountants, as Auditors to the Company will be submitted at the Annual General Meeting.

The Auditors Report is found in the Financial Information section of the Annual Report.

The Auditors, Messrs. Ernst & Young, Chartered Accountants were paid Rs. 1,637,100/- (2015 – Rs. 1,549,544/-) and Rs. 3,117,411/- (2015 -Rs. 2,910,366/- Mn) as audit fees by the Company and the Group respectively. In addition, they were paid Rs. 920,350/- (2015-Rs. 348,790/-) and Rs. 2,972,617/- (2015 - Rs. 1,063,930/-), by the Company and the Group, for permitted non-audit related services.

The Auditors have confirmed that they do not have any relationship with or interest in the Company other than those disclosed above.

Annual General Meeting

The Annual General Meeting will be held on 24th April 2017 at 3.30 p.m at the Havelock City Club House, No. 324, Havelock Road, Colombo 06. The Notice of the Annual General Meeting appears on page 123 of the Annual Report.

For and on behalf of the Board



H. Z. Cassim
Director

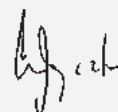

Ajith M. de S. Jayaratne
Director

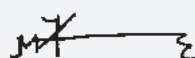

Minoka Samaranayake
Company Secretary

09th February 2017

Directors, Statement on Internal Controls

The following statement fulfills the requirement to publish the Directors' Statement on Internal Control as per the Code of Best Practice on Corporate Governance issued by CA Sri Lanka and Securities and Exchange Commission of Sri Lanka.

The Board of Directors is responsible for maintaining a sound system of internal controls to safeguard Shareholders' Investments and the Company's Assets. The Board has established an ongoing process for identifying, evaluating and managing the significant risks faced by the Company and the Group. This process includes enhancing the system of internal controls as and when there are changes to business environment or regulatory guidelines. The process is regularly reviewed by the Board.

The Board is of the view that the system of internal controls in place is sound and adequate to provide reasonable assurance regarding the reliability of financial reporting, and the preparation of Financial Statements for external purposes and is in accordance with relevant accounting principles and regulatory requirements.

The Board has implemented the following to obtain reasonable assurance that proper systems of internal controls are in place:

- Instituted various committees to assist the Board in ensuring the effectiveness of Company's operations and the operations are in accordance with the corporate strategies and annual budget.
- The Company's internal audit function has been outsourced to Messrs. Pricewaterhouse Coopers (PWC) (Chartered Accountants). The Internal Auditors check for compliance with policies and procedures and the effectiveness of the internal control systems on an ongoing basis using samples and rotational procedures and the highlight significant findings in respect of any non-compliance. Audits are carried out on all subsidiaries in accordance with the annual audit plan approved by the Audit Committee. Findings are submitted to the Audit Committee for review at their periodic meetings.
- The Audit Committee reviews internal control issues identified by Internal Auditors, and evaluates the adequacy and effectiveness of the risk management and internal control systems. They also review the internal audit functions with particular emphasis on the scope of audits and quality of internal audits. The

minutes of the Audit Committee meetings are tabled at the Board meetings for the information of the Board on a periodic basis.

- In assessing the internal control system over financial reporting, relevant senior officers of the company collated all procedures and control that are connected with significant accounts and disclosures of the Financial Statement of the Company. These in turn were observed and checked by the Internal Auditors for suitability of design and effectiveness on an ongoing basis.
- The adoption of new Sri Lanka Accounting Standards comprising SLFRS and LKAS in 2012, processes that are required to comply with new requirements of recognition, measurement, presentation and disclosures were introduced and implemented. Continuous monitoring is in progress to ensure effective implementation of the required processes.
- The comments made by External Auditors in connection with the internal control system during the financial year 2016 were taken into consideration and appropriate steps have been taken to rectify them.

Conclusion

Based on the above processes, the Board of Directors confirms that the financial reporting system of the Company has been designed to provide reasonable assurance regarding the reliability of financial reporting and the preparation of Financial Statements for external purposes have been done in accordance with the Sri Lanka Accounting Standards (SLFRS/ LKAS), requirements of the Company's Act No. 07 of 2007 and the Listing Rules of the Colombo Stock Exchange.



H. Z. Cassim
Deputy Chairman



Ajith M. de S. Jayaratne
Chairman, Audit Committee

09th February 2017

Directors' Responsibility for Financial Reporting

The Directors of the Company are responsible for the preparation and presentation of the Financial Statements to the shareholders in accordance with the relevant provisions of the Companies Act No. 07 of 2007 and other statutes which are applicable in preparation of Financial Statements.

The consolidated Financial Statements of the Company and its Subsidiaries comprise of:

- Statement of Financial position as at 31 December 2016, which present a true and fair view of the state of affairs of the Company and its subsidiaries as at the end of the financial year and
- Income Statements which presents a true and fair view of the profit and loss of the Company and its subsidiaries for the financial year then ended.

Accordingly, the Directors confirm that the Financial Statements of the Company and its subsidiaries for the year ended 31 December 2016 incorporated in this report have been prepared in accordance with the Companies Act No. 07 of 2007, Sri Lanka Accounting Standards (SLFRS/LKAS), Listing Rules of the Colombo Stock Exchange and generally accepted accounting policies. The Directors consider that, in preparing the Financial Statements exhibited on pages 64 to 115 they have adopted appropriate accounting policies on a consistent basis, supported by reasonable and prudent judgments and estimates.

The Directors are also responsible for taking reasonable steps to safeguard the assets of the Company and to prevent and detect frauds and other irregularities. In this regard, the Directors have instituted an effective and comprehensive system of internal controls comprising of internal checks, internal audit, financial and other controls required to carry on the Company's business in an orderly manner and to safeguard its assets and secure as far as practicable the accuracy and reliability of the records.

Messrs. Ernst & Young, Chartered Accountants, have carried out an audit in accordance with Sri Lanka Auditing Standards and their report is given on page 63 of the Annual Report.

The Directors have provided the Auditors with every opportunity to carry out any reviews and tests that they consider appropriate and necessary for the performance of their responsibilities.

Further, as required by Section 56(2) of the Companies Act No. 07 of 2007, the Board of Directors have confirmed that the Company based on the information available, satisfies the solvency test immediately after the distribution, in accordance with Section 57 of the Companies Act No. 07 of 2007 and has obtained a certificate from the auditors, prior to recommending a final dividend of Rs. 1.25 per share for this year which is to be approved by the shareholders at the Annual General Meeting to be held on 24th April 2017.

The Directors are of the view that they have discharged their responsibilities as set out in this statement.

The Directors confirm to the best of their knowledge that all taxes, levies and financial obligations of the Group have been either paid or adequately provided for in the Financial Statements, except as specified in Note 28 to the Financial Statements covering contingent liabilities.

For and on behalf of the Board



H. Z. Cassim
Deputy Chairman

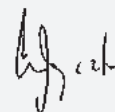

A. M. de S. Jayaratne
Director

09th February 2017

Independent Auditors' Report



Ernst & Young
Chartered Accountants
201 De Saram Place
P.O. Box 101
Colombo 10
Sri Lanka

Tel : +94 11 2463500
Fax Gen : +94 11 2697369
Tax : +94 11 5578180
eysl@lk.ey.com
ey.com

TO THE SHAREHOLDERS OF OVERSEAS REALTY (CEYLON) PLC

Report on the Financial Statements

We have audited the accompanying financial statements of Overseas Realty (Ceylon) PLC ("the Company"), the consolidated financial statements of the Company and its subsidiaries ("Group") which comprise the statement of financial position as at 31 December 2016, and the statement of profit or loss, statement of comprehensive income, statements of changes in equity and statement cash flows for the year then ended, and a summary of significant accounting policies and other explanatory information.

Board's Responsibility for the Financial Statements

The Board of Directors ("Board") is responsible for the preparation of these financial statements that give a true and fair view in accordance with Sri Lanka Accounting Standards, and for such internal controls as Board determines is necessary to enable the preparation of financial statements that are free from material misstatement, whether due to fraud or error.

Auditor's Responsibility

Our responsibility is to express an opinion on these financial statements based on our audit. We conducted our audit in accordance with Sri Lanka Auditing Standards. Those standards require that we comply with ethical requirements and plan and perform the audit to obtain reasonable assurance about whether the financial statements are free from material misstatement.

An audit involves performing procedures to obtain audit evidence about the amounts and disclosures in the financial statements. The procedures selected depend on the auditor's judgment, including the assessment of the risks of material misstatement of the financial statements, whether due to fraud or error. In making those risk assessments, the auditor considers internal control relevant to the entity's preparation of the financial statements that give a true and fair view in order to design audit procedures that are appropriate in the circumstances, but not for the purpose of expressing an opinion on the effectiveness of the entity's internal control. An audit also includes evaluating the appropriateness of accounting policies used and the reasonableness of accounting

estimates made by Board, as well as evaluating the overall presentation of the financial statements.

We believe that the audit evidence we have obtained is sufficient and appropriate to provide a basis for our audit opinion.

Opinion

In our opinion, the consolidated financial statements give a true and fair view of the financial position as at 31 December 2016, and of its financial performance and cash flows for the year then ended in accordance with Sri Lanka Accounting Standards.

Report on other legal and regulatory requirements

As required by Section 163(2) of the Companies Act No. 7 of 2007, we state the following:

- The basis of opinion, scope and limitations of the audit are as stated above.
- In our opinion :
 - we have obtained all the information and explanations that were required for the audit and, as far as appears from our examination, proper accounting records have been kept by the Company,
 - the financial statements of the Company give a true and fair view of the financial position as at 31 December 2016, and of its financial performance and cash flows for the year then ended in accordance with Sri Lanka Accounting Standards, and
 - the financial statements of the Company and the Group, comply with the requirements of Section 151 and 153 of the Companies Act No. 07 of 2007.

09th February 2017

Colombo

Partners: W R H Fernando FCA FCMA M P D Cooray FCA FCMA R N de Saram ACA FCMA Ms. N A De Silva FCA Ms. Y A De Silva FCA W K B S P Fernando FCA FCMA
Ms. K R M Fernando FCA ACMA Ms. L K H L Fonseka FCA A P A Gunasekera FCA FCMA A Herath FCA D K Mulangamuwa FCA FCMA LLB (Lond) H M A Jayasinghe FCA FCMA
Ms. A A Ludowyke FCA FCMA Ms. G G S Manalunga FCA N M Sulaiman ACA ACMA B E Wijesuriya FCA FCMA

Principal T P M Ruberu FCA FCMA

A member firm of Ernst & Young Global Limited

Statement of Financial Position

As at 31 December 2016

	Note	Group		Company	
		2016 Rs.	2015 Rs.	2016 Rs.	2015 Rs.
ASSETS					
Non-Current Assets					
Investment Property	5	24,651,770,855	22,579,410,997	23,840,698,855	22,579,410,997
Property, Plant and Equipment	6	1,782,027,248	1,598,105,407	391,285,879	363,934,865
Intangible Assets	7	2,064,070	12,329,186	2,064,070	3,534,322
Investments in Subsidiaries	8	-	-	5,768,534,644	1,125,010,040
Inventories	10.1	3,193,406,720	2,362,174,072	-	-
Deferred Tax Assets	9	149,251,175	29,364,154	8,906,643	15,490,202
		29,778,520,068	26,581,383,816	30,011,490,091	24,087,380,426
Current Assets					
Inventories	10.2	93,957,951	271,599,468	13,241,224	15,615,804
Trade and Other Receivables	11	1,475,330,643	892,180,991	395,259,153	423,400,072
Amounts due from Related Parties	12	-	996,488	11,409,806	9,843,740
Income Tax Recoverable		16,656,190	-	-	-
Short Term Investments	15.1	1,472,627,772	2,861,711,243	1,437,083,277	2,861,711,243
Cash and Short Term Deposits	21	1,343,889,282	1,666,099,117	462,716,662	1,400,284,722
		4,402,461,838	5,692,587,307	2,319,710,122	4,710,855,581
Total Assets		34,180,981,906	32,273,971,123	32,331,200,213	28,798,236,007
EQUITY AND LIABILITIES					
Equity Attributable to Equity Holders of the Parent					
Stated Capital	13	11,162,751,513	11,162,751,513	11,162,751,513	11,162,751,513
Revaluation Reserve	14	464,046,014	291,182,354	320,266,949	284,081,947
Retained Earnings		16,206,652,106	17,151,060,831	17,585,079,914	15,992,500,341
		27,833,449,633	28,604,994,698	29,068,098,376	27,439,333,801
Non-controlling Interest		-	1,511,844,687	-	-
Total Equity		27,833,449,633	30,116,839,385	29,068,098,376	27,439,333,801
Non-Current Liabilities					
Interest Bearing Loans and Borrowings	15.2	-	45,797,000	-	45,797,000
Post Employment Benefit Liability	16	26,556,246	26,511,177	14,530,990	11,650,115
Customer Deposits	18	1,214,792,590	322,786,412	-	-
Deferred Tax Liabilities	9	226,329,203	22,708,034	-	-
		1,467,678,039	417,802,623	14,530,990	57,447,115
Current Liabilities					
Trade and Other Payables	17	884,751,116	782,166,170	339,186,628	329,331,292
Rental Deposits	18	856,450,089	875,469,328	841,728,195	875,469,328
Amounts due to Related Parties	19	793,610,010	21,171,041	37,793,185	24,436,521
Interest Bearing Loans and Borrowings	15.2	2,304,373,168	50,004,000	1,993,847,000	50,004,000
Income Tax Payable		27,372,755	3,805,402	22,718,743	15,500,776
Dividends Payable	20	13,297,096	6,713,174	13,297,096	6,713,174
		4,879,854,234	1,739,329,115	3,248,570,847	1,301,455,091
Total Liabilities		6,347,532,273	2,157,131,738	3,263,101,837	1,358,902,206
Total Equity and Liabilities		34,180,981,906	32,273,971,123	32,331,200,213	28,798,236,007

I certify that these Financial Statements are in compliance with the requirements of the Companies Act No. 07 of 2007.

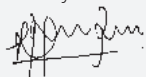

Roschen Perera
Group Chief Financial Officer

The Board of Directors is responsible for the preparation and presentation of these Financial Statements. Signed for and on behalf of the Board by,



H. Z. Cassim
Director

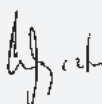

A. M. de S. Jayaratne
Director

The accounting policies and notes on pages 69 through 115 form an integral part of the Financial Statements.

09th February 2017
Colombo

Statement of Profit or Loss

Year ended 31 December 2016					
	Note	Group		Company	
		2016 Rs.	2015 Rs.	2016 Rs.	2015 Rs.
Rental Revenue	3	1,886,277,287	1,962,481,494	1,859,225,262	1,962,481,494
Sale of Apartments		285,146,935	973,585,939	-	-
Other Services	4	259,308,797	204,598,678	47,696,512	46,488,998
Total Revenue	3	2,430,733,019	3,140,666,111	1,906,921,774	2,008,970,492
Direct Operating Expenses		(615,052,032)	(548,356,881)	(423,224,791)	(421,437,467)
Cost of Sales of Apartments		(159,685,351)	(652,623,361)	-	-
Gross Profit		1,655,995,636	1,939,685,869	1,483,696,983	1,587,533,025
Fair Value Gain on Investment Property	5	1,267,315,858	1,174,538,190	1,261,287,858	1,174,538,190
Administration Expenses		(267,552,578)	(265,394,896)	(175,731,230)	(162,054,729)
Marketing and Promotional Expenses		(55,411,940)	(39,105,751)	-	-
Operating Profit		2,600,346,976	2,809,723,412	2,569,253,611	2,600,016,486
Finance Cost	22.1	(54,576,893)	(12,339,271)	(43,765,600)	(5,140,030)
Finance Income	22.2	331,786,502	181,572,958	303,905,573	173,298,077
Other Income	22.3	85,264,640	84,289,181	110,411,725	115,959,244
Exchange Gain		11,032,104	9,664,790	3,988,262	5,887,498
Profit Before Tax	23	2,973,853,329	3,072,911,070	2,943,793,571	2,890,021,275
Income Tax	24.1	(43,735,828)	(42,057,643)	(18,810,169)	(23,209,026)
Profit after Tax for the Year		2,930,117,501	3,030,853,427	2,924,983,402	2,866,812,249
Attributable to:					
Equity Holders of the Parent		2,911,371,018	2,990,698,564		
Non-controlling Interest		18,746,483	40,154,863		
		2,930,117,501	3,030,853,427		
Earnings Per Share - Basic/Diluted	25	3.28	3.44		
Dividend Per Share	20	1.50	1.50		

The accounting policies and notes on pages 69 through 115 form an integral part of the Financial Statements.

Statement of Comprehensive Income

Year ended 31 December 2016					
	Note	Group		Company	
		2016	2015	2016	2015
		Rs.	Rs.	Rs.	Rs.
Profit For the Year		2,930,117,501	3,030,853,427	2,924,983,402	2,866,812,249
Other Comprehensive Income:					
Items that will not be reclassified to profit or loss:					
Revaluation of Buildings	14.1	50,708,051	33,572,583	36,185,002	19,558,556
Deferred Tax Effect		(2,178,457)	(2,180,016)	-	-
		48,529,594	31,392,567	36,185,002	19,558,556
Actuarial Gains/(Losses) on Defined Benefit Plans	16	(2,641,492)	1,090,965	(586,419)	(513,224)
Deferred Tax Effect		334,942	(866,903)	-	-
		(2,306,550)	224,062	(586,419)	(513,224)
Other Comprehensive Income for the Year, Net of Tax		46,223,043	31,616,629	35,598,583	19,045,332
Total Comprehensive Income for the Year, Net of Tax		2,976,340,544	3,062,470,056	2,960,581,985	2,885,857,581
Attributable to:					
Equity Holders of the Parent		2,953,285,169	3,018,674,115		
Non-controlling Interest		23,055,375	43,795,941		
		2,976,340,544	3,062,470,056		

The accounting policies and notes on pages 69 through 115 form an integral part of the Financial Statements.

Statement of Changes in Equity

Year ended 31 December 2016	Note	Stated Capital Rs.	Revaluation Reserve Rs.	Retained Earnings Rs.	Total Rs.	Non-controlling Interest Rs.	Total Equity Rs.
Group							
Balance as at 1 January 2015		10,186,085,405	264,523,391	15,477,908,704	25,928,517,500	1,507,482,118	27,435,999,618
Super Gain Tax Paid	2.3.16	-	-	(47,079,857)	(47,079,857)	(1,933,372)	(49,013,229)
Profit for the Year		-	-	2,990,698,564	2,990,698,564	40,154,863	3,030,853,427
Other Comprehensive Income for the Year		-	26,658,963	1,316,588	27,975,551	3,641,078	31,616,629
Issue of Ordinary Shares	13	976,666,108	-	-	976,666,108	-	976,666,108
Transaction Cost Relating to Share Issue		-	-	(6,556,629)	(6,556,629)	-	(6,556,629)
Dividends Paid for Ordinary Shares for Y/E 31/12/2014	20	-	-	(1,265,226,539)	(1,265,226,539)	-	(1,265,226,539)
Subsidiary Dividends Paid for Non controlling interest for Y/E 31/12/2014		-	-	-	-	(37,500,000)	(37,500,000)
Balance as at 31 December 2015		11,162,751,513	291,182,354	17,151,060,831	28,604,994,698	1,511,844,687	30,116,839,385
Profit for the Year		-	-	2,911,371,018	2,911,371,018	18,746,483	2,930,117,501
Other Comprehensive Income for the Year		-	43,591,756	(1,677,606)	41,914,150	4,308,893	46,223,043
Adjustments Relating to Business Combination	8.2	-	129,271,904	(139,684,790)	(10,412,886)	-	(10,412,886)
Dividends Paid for Ordinary Shares for Y/E 31/12/2015	20	-	-	(1,331,817,410)	(1,331,817,410)	-	(1,331,817,410)
Subsidiary Dividends Paid for Non controlling interest for Y/E 31/12/2015		-	-	(2,382,599,937)	(2,382,599,937)	(37,500,000)	(37,500,000)
Acquisition of Non Controlling Interest	8.3	-	-	(1,497,400,063)	(1,497,400,063)	(3,880,000,000)	(3,880,000,000)
Balance as at 31 December 2016		11,162,751,513	464,046,014	16,206,652,106	27,833,449,633	-	27,833,449,633
Company			Note	Stated Capital Rs.	Revaluation Reserve Rs.	Retained Earnings Rs.	Total Rs.
Balance as at 1 January 2015		10,186,085,405		14,441,644,747	264,523,391	14,441,644,747	24,892,253,543
Super Gain Tax Paid		-	2.3.16	-	-	(43,660,263)	(43,660,263)
Profit for the Year		-		-	-	2,866,812,249	2,866,812,249
Other Comprehensive Income for the Year		-		-	19,558,556	(513,224)	19,045,332
Issue of Ordinary Shares		976,666,108	13	976,666,108	-	-	976,666,108
Transaction Cost Relating to Share Issue		-		-	-	(6,556,629)	(6,556,629)
Dividends Paid on Ordinary Shares for Y/E 31/12/2014		-	20	-	-	(1,265,226,539)	(1,265,226,539)
Balance as at 31 December 2015		11,162,751,513		284,081,947	15,992,500,341	15,992,500,341	27,439,333,801
Profit for the Year		-		-	-	2,924,983,402	2,924,983,402
Other Comprehensive Income for the Year		-		-	36,185,002	(586,419)	35,598,583
Dividends Paid on Ordinary Shares for Y/E 31/12/2015		-		-	-	(1,331,817,410)	(1,331,817,410)
Balance as at 31 December 2016		11,162,751,513		320,266,949	17,585,079,914	17,585,079,914	29,068,098,376

The accounting policies and notes on pages 69 through 115 form an integral part of the Financial Statements.

Statement of Cash Flows

Year ended 31 December 2016		Group		Company	
	Note	2016 Rs.	2015 Rs.	2016 Rs.	2015 Rs.
Cash Flows from Operating Activities:					
Profit Before Tax Expense		2,973,853,329	3,072,911,070	2,943,793,571	2,890,021,275
Adjustments for -					
Depreciation Charge for the Year	6	33,546,040	30,518,480	12,686,369	10,637,753
Amortization / write-off of Intangible Assets	7	10,265,116	1,470,252	1,470,252	1,470,252
Post Employment Benefit Expense	16	5,949,374	6,477,655	2,971,391	2,784,621
Finance Cost	22.1	54,576,893	12,339,271	43,765,600	5,140,030
Finance Income	22.2	(331,786,502)	(181,572,958)	(303,905,573)	(173,298,077)
(Profit)/Loss on Disposal of Property, Plant and Equipment		(3,871,489)	(5,952,721)	(3,871,489)	(5,952,721)
Fair Value (Gain) on Investment Property	5	(1,267,315,858)	(1,174,538,190)	(1,261,287,858)	(1,174,538,190)
Operating Profit before Working Capital Changes		1,475,216,904	1,761,652,859	1,435,622,263	1,556,264,943
(Increase)/ Decrease in Amounts due from Related Parties		996,488	7,669,803	(1,566,066)	2,214,299
(Increase) / Decrease in Trade and Other Receivables		(583,149,652)	486,539,428	28,140,919	(67,942,987)
Increase / (Decrease) in Rental and Customer Deposits		872,986,939	294,019,470	(33,741,133)	34,771,175
(Increase) / Decrease in Inventories		(739,735,826)	(85,173,260)	2,374,580	3,614,583
Increase / (Decrease) in Trade and Other Payables		102,584,946	(43,057,905)	9,855,336	(4,991,382)
Increase/ (Decrease) in Amounts due to Related Parties		64,488,114	21,171,041	13,604,660	19,778,890
Cash Generated From Operations		1,193,387,913	2,442,821,436	1,454,290,559	1,543,709,521
Income Tax Paid		(16,678,000)	(61,832,606)	(5,008,639)	(43,114,226)
Finance Cost Paid	22.1	(54,576,893)	(12,339,271)	(43,765,600)	(5,140,030)
Defined Benefit Plan Costs Paid	16	(3,671,567)	(150,255)	(924,935)	-
Net Cash Generated From Operating Activities		1,118,461,452	2,368,499,304	1,404,591,385	1,495,455,265
Cash Flows from Investing Activities :					
Proceeds from Sale of Property, Plant and Equipment		3,871,489	5,952,721	3,871,489	5,952,721
Acquisition of Property Plant and Equipment	6	(80,615,134)	(35,939,895)	(3,852,381)	(16,557,912)
(Acquisition) / disposals of Investment	15.1	1,630,229,447	(609,609,045)	1,630,229,447	(609,609,045)
Acquisition of Subsidiary, net of cash acquired	8.2	(42,067,056)	-	-	-
Investment in Subsidiaries		-	-	(4,643,524,604)	-
Acquisition of Non Controlling Interest	8.3	(3,880,000,000)	-	-	-
Finance Income Received		82,071,287	84,205,818	98,304,092	75,930,937
Net Cash From Investing Activities		(2,286,509,967)	(555,390,401)	(2,914,971,957)	(544,283,299)
Cash Flows from Financing Activities :					
Repayment of Interest Bearing Loans and Borrowings	15.2	(50,004,000)	(970,504,000)	(50,004,000)	(50,004,000)
Dividends Paid		(1,362,733,488)	(1,301,328,890)	(1,325,233,488)	(1,263,828,890)
Proceeds from Issue of Shares (Rights Issue)		-	976,666,108	-	976,666,108
Direct Expenses Related to Rights Issue		-	(6,556,629)	-	(6,556,629)
Proceeds from Interest Bearing Loans and Borrowings	15.2	309,425,153	-	-	-
Net Cash Flow from/(Out Flow) Financing Activities		(1,103,312,335)	(1,301,723,411)	(1,375,237,488)	(343,723,411)
Net Increase/ (Decrease) in Cash and Cash Equivalents		(2,271,360,850)	511,385,492	(2,885,618,060)	607,448,555
Cash and Cash Equivalents at the Beginning of the Year	21	1,666,099,117	1,154,713,625	1,400,284,722	792,836,167
Cash and Cash Equivalents at the End of the Year	21	(605,261,733)	1,666,099,117	(1,485,333,338)	1,400,284,722

The accounting policies and notes on pages 69 through 115 form an integral part of the Financial Statements.

Notes to the Financial Statements

Year ended 31 December 2016

1. CORPORATE INFORMATION

1.1 General

Overseas Realty (Ceylon) PLC (“Company”) is a Public Quoted Company with limited liability incorporated and domiciled in Sri Lanka. The registered office of the Company is located at Level # 18-01, East Tower, World Trade Center, Colombo 01, which is the principal place of its business.

1.2 Principal Activities and Nature of Operations

During the year, the principal activities of the Company were property Leasing, property services and property trading.

Mireka Capital Land (Private) Limited, a subsidiary, is engaged in purchasing, hiring and acquiring real estate properties, real estate development and providing infrastructure facilities to the Havelock City development project.

Mireka Homes (Private) Limited, a sub-subsidiary, is engaged in constructing and developing the Havelock City condominium development and related infrastructure and is involved in the sale, lease, management or any similar transactions in respect of the same and any other business carried on by land investment, land development and real estate companies.

SK Investments Lanka (Private) Limited, a subsidiary, is engaged in renting of Level 36 & 37 of East Tower, World Trade Center, Colombo 01.

Realty Management Services (Private) Limited, a subsidiary, is engaged in renting and providing absentee landlord management of Havelock City condominiums on behalf of its owners and also providing facility management services and trading of lighting solution.

Other subsidiaries of the Company have not been operational during the year.

1.3 Parent Entity and Ultimate controlling party

In the opinion of the Directors, the Company’s parent entity is the Shing Kwan Group headquartered in Singapore and Mr. Shing Pee Tao is the ultimate controlling party.

1.4 Date of Authorization for Issue

The Financial Statements of Overseas Realty (Ceylon) PLC for the year ended 31 December 2016 were authorised for issue in accordance with a resolution of the Board of Directors on 09 February 2017.

2. BASIS OF PREPARATION

The Consolidated Financial Statements of the Company have been prepared in accordance with Sri Lanka Accounting Standards comprising SLFRS and LKAS (hereafter referred as “SLFRS”) as issued by the Institute of Chartered Accountants of Sri Lanka (CA Sri Lanka).

The consolidated financial statements have been prepared on a historical cost basis, except for investment properties, buildings classified as property, plant and equipment, short term investments that have been measured at fair value.

These Financial Statements are presented in Sri Lankan Rupees. The preparation and presentation of these Financial Statements are in compliance with the Companies Act No. 07 of 2007.

2.1.1 Changes in Accounting Policies

The accounting policies adopted are consistent with those of the previous year.

2.1.2 Consolidation Policies

The consolidated financial statements comprise the financial statements of the Group and its subsidiaries as at the reporting date. Control is achieved when the Group is exposed, or has rights to variable returns from its involvement with the investee and has the ability to affect those returns through its power over the investee.

Specifically, the Group controls an investee if and only if the Group has:

- Power over the investee (i.e. existing rights that give it the current ability to direct the relevant activities of the investee)
- Exposure, or rights, to variable returns from its involvement with the investee, and

Notes to the Financial Statements

Year ended 31 December 2016

- The ability to use its power over the investee to affect its returns

When the Group has less than a majority of the voting or similar rights of an investee, the Group considers all relevant facts and circumstances in assessing whether it has power over an investee, including:

- The contractual arrangement with the other vote holders of the investee
- Rights arising from other contractual arrangements
- The Group's voting rights and potential voting rights

The Group re-assesses whether or not it controls an investee if facts and circumstances indicate that there are changes to one or more of the three elements of control. Consolidation of a subsidiary begins when the Group obtains control over the subsidiary and ceases when the Group loses control of the subsidiary. Assets, liabilities, income and expenses of a subsidiary acquired or disposed of during the year are included in the statement of comprehensive income from the date the Group gains control until the date the Group ceases to control the subsidiary.

The financial statements of the subsidiaries are prepared for the same reporting period as the parent company, using consistent accounting policies. All intra-group balances, transactions, unrealised gains and losses resulting from intra-group transactions and dividends are eliminated in full.

Losses within a subsidiary are attributed to the non-controlling interest even if that results in a deficit balance.

A change in the ownership interest of a subsidiary, without a loss of control, is accounted for as an equity transaction. If the Group loses control over a subsidiary, it:

- Derecognises the assets (including goodwill) and liabilities of the subsidiary
- Derecognises the carrying amount of any non-controlling interests

- Derecognises the cumulative translation differences recorded in equity

- Recognises the fair value of the consideration received

- Recognises the fair value of any investment retained

- Recognises any surplus or deficit in profit or loss

- Reclassifies the parent's share of components previously recognised in Other Comprehensive Income to profit or loss or retained earnings, as appropriate, as would be required if the Group had directly disposed of the related assets or liabilities.

The following companies have been consolidated.

- Mireka Capital Land (Private) Limited (Subsidiary)
- Mireka Homes (Private) Limited (Sub-subsidiary)
- Realty Management Services (Private) Limited (Subsidiary)
- SK Investments Lanka (Private) Limited (Subsidiary)
- Hospitality International (Private) Limited (Subsidiary)
- Property Mart (Private) Limited (Subsidiary)
- Havelock City (Private) Limited (Sub-Subsidiary)
- Mireka Residencies (Private) Limited (Sub-subsidiary)
- Mireka Property (Private) Limited (Sub-subsidiary)

2.1.3 Segment Reporting

A business segment is a group of assets and operations engaged in providing products or services that are subject to risks and returns that are different from those of other business segments. The primary segment reporting format is determined to be a business segment.

2.2 Significant Accounting Judgments, Estimates and Assumptions

2.2.1 Critical Judgments in Applying the Accounting Policies

In the process of applying the Group's accounting policies, management has made the following judgments, apart from those involving estimations, which has the most significant effect on the amounts recognized in the Financial Statements.

(a) Classification of Property

The Group determines whether a property is classified as Investment Property, owner occupied property or inventories, using significant judgment as disclosed in Note 5 and Note 6.

Investment Property comprises land and buildings which are not occupied substantially for use by, or in the operations of the Group, nor for sale in the ordinary course of business, but are held primarily to earn rental income and capital appreciation.

The Group determines whether a property qualifies as Investment Property by considering whether the property generates cash flows largely independently of the other assets held by the entity. Owner-occupied properties generate cash flows that are attributable not only to property but also to other assets used in the production or supply process.

Some properties comprise a portion that is held to earn rentals or for capital appreciation and another portion that is held for use in the production or supply of goods or services or for administrative purposes. If these portions can be sold separately (or leased out separately under a finance lease), the Group accounts for the portions separately. If the portions cannot be sold separately, the property is accounted for as Investment Property only if an insignificant portion is held for use in the production or supply of goods or services or for administrative purposes. Judgment is applied in determining whether ancillary services are so significant that a property does not qualify as Investment Property. The Group considers each property separately in making its judgment.

Inventory comprises property that is held for sale in the ordinary course of business. Principally, this is residential property that the Group develops and intends to sell before, during and/or on completion of construction.

(b) Revenue recognition from sale of apartments

In recognizing revenue from sale of apartments, management applies judgment ascertaining if the risks and rewards of ownership have passed to the buyers. In this regard, management sought professional legal advice in determining the point at which equitable interest passes to the buyer and accordingly recognizes revenue under the percentage of completion method as the Group continuously transfers to the buyer significant risks and rewards of ownership of the work in progress in its current state as the construction progress.

(c) Deferred Taxation

Deferred taxation on Investment Property and owner occupied property (property)

As per the LKAS 12, deferred tax on Property carried at fair value is required to be measured using a rebuttable presumption that the carrying amount will be recovered through sale.

The property of the company consists of freehold land and buildings. With regard to the building, the pre-sumption is rebutted, as the company's business model is to consume substantially all the economic benefits embodied in the building over time, rather than through sale. The land component of the property does not create any tax consequences, as currently capital gain tax is not applicable for land.

As described in Note 2.3.3, the company enjoys tax exemption status up to the year 2020, and thereafter till 2035, company will be taxed based on its turnover. Accordingly temporary differences will not arise on the property up to the year 2035.

In the event the building component is sold after the year 2035, it will create tax consequences. However the management believes the fair value of the building component of the property will not be material as a significant proportion of the useful life of the building will have been consumed by them.

Notes to the Financial Statements

Year ended 31 December 2016

Based on the above, Management believes that deferred tax in respect of Property will not be material to the financial statements.

2.2.2 Critical Accounting Estimates and Assumptions

The key assumptions concerning the future and other key sources of estimation of uncertainty at the reporting date, that have a significant risk of causing material adjustments to the carrying amounts of assets and liabilities within the next financial year are discussed below. The respective carrying amounts of assets and liabilities are given in related notes to the Financial Statements.

(a) Estimation of fair value of Investment Properties

The Group carries its Investment Properties at fair value, with changes in fair values being recognised in the Statement of Profit or Loss. The Group engaged an independent valuer to determine the fair value as at 31 December 2016.

The best evidence of fair value is usually the current price in an active market for similar lease and other contracts. In the absence of such information, the Group determines the amount within a range of reasonable fair value estimates. In making such estimates, the Group considers information from a variety of sources including:

- (i) Current prices in an active market for properties of different nature, condition or location (or subject to different lease or other contracts), adjusted to reflect those differences;
- (ii) Recent prices of similar properties in less active markets, with adjustments to reflect any changes in economic conditions since the date of the transactions that occurred at those prices; and
- (iii) Discounted cash flow projections based on reliable estimates of future cash flows, derived from the terms of any existing lease and other contracts and (where possible) from external evidence such as current market rents for similar properties in the same location and condition, and using capitalization rates that reflect current market assessments of the returns and yields, and uncertainty in the amount and timing of the cash flows.

(b) Principal assumptions for management's estimation of fair value

If information on current or recent prices of assumptions underlying the discounted cash flow approach of Investment Properties is not available, the fair values of Investment Properties are determined using discounted cash flow valuation techniques. The Group uses assumptions that are mainly based on market conditions existing at each reporting date.

The principal assumptions underlying management's estimation of fair value are those related to: the future rentals, maintenance requirements, and appropriate capitalization rates / yields and voids. These valuations are regularly compared to actual market yield data and actual transactions by the Group and those reported by the market.

The determined fair value of the Investment Properties is most sensitive to the capitalization rate, anticipated maintenance cost as well as the rate of growth in future rentals as given in Note 5.2.

Therefore management has carried out a sensitivity analysis in relation to the key assumptions used in valuing the Investment Property as disclosed in Note 5.3.

(c) Deferred Taxation

Deferred tax assets are recognised for all unused tax losses to the extent that it is probable that taxable profit will be available against which the losses can be utilised. Significant management judgement is required to determine the amount of deferred tax that can be recognised based upon the likely timing and the levels of future taxable profits. More information regarding deferred tax assets is given in Note 9 and 24.

2.3 Summary of Significant Accounting Policies

2.3.1 Business Combinations and Goodwill

Business combinations are accounted for using the acquisition method. The cost of an acquisition is measured as the aggregate of the consideration transferred, measured at acquisition date fair value and the amount of any non-controlling interest in the acquiree. For each business combination, the

Group elects whether it measures the non-controlling interest in the acquiree either at fair value or at the proportionate share of the acquiree's identifiable net assets. Acquisition costs incurred are expensed and included in administrative expenses.

When the Group acquires a business, it assesses the financial assets and liabilities assumed for appropriate classification and designation in accordance with the contractual terms, economic circumstances and pertinent conditions as at the acquisition date. This includes the separation of embedded derivatives in host contracts by the acquiree.

If the business combination is achieved in stages, the acquisition date fair value of the acquirer's previously held equity interest in the acquiree is remeasured to fair value at the acquisition date through profit or loss.

Any contingent consideration to be transferred by the acquirer will be recognised at fair value at the acquisition date. Subsequent changes in the fair value of the contingent consideration which is deemed to be an asset or liability will be recognised in accordance with LKAS 39 either in profit or loss or as a change to other comprehensive income. If the contingent consideration is classified as equity, it will not be remeasured. Subsequent settlement is accounted for within equity. In instances where the contingent consideration does not fall within the scope of LKAS 39, it is measured in accordance with the appropriate SLFRS/LKAS.

Goodwill is initially measured at cost, being the excess of the aggregate of the consideration transferred and the amount recognised for non-controlling interest over the net identifiable assets acquired and liabilities assumed. If this consideration is lower than the fair value of the net assets of the subsidiary acquired, the difference is recognised in profit or loss.

After initial recognition, goodwill is measured at cost less any accumulated impairment losses. For the purpose of impairment testing, goodwill acquired in a business combination is, from the acquisition date, allocated to each of the Group's cash-generating units that are expected to benefit from the combination, irrespective of whether other assets or liabilities of the acquiree are assigned to those units.

Where goodwill forms part of a cash-generating unit and part of the operation within that unit is disposed of, the goodwill associated with the operation disposed of is included in the carrying amount of the operation when determining the gain or loss on disposal of the operation. Goodwill disposed of in this circumstance is measured based on the relative values of the operation disposed of and the portion of the cash-generating unit retained.

The business combination under common control transaction taken place during the year is accounted by using pooling of interest method.

2.3.2 Foreign Currency Translation

The Financial Statements are presented in Sri Lankan Rupees, which is the Group's functional and presentation currency. Transactions in foreign currencies are initially recorded at the functional currency rate ruling at the date of the transaction. Monetary assets and liabilities denominated in foreign currencies are retranslated at the functional currency rate of exchange ruling at the reporting date. All differences are taken to profit or loss. Non-monetary items that are measured in terms of historical cost in a foreign currency are translated using the exchange rates as at the dates of the initial transactions. All exchange variances are charged to the Statement of Profit or Loss.

2.3.3 Taxation

Current Taxes

Companies in the Group have entered into agreements with the Board of Investment of Sri Lanka (BOI), as specified below. Such agreements specify that the sections of the Inland Revenue Act relating to the imposition, payment and recovery of income tax should not apply to the respective companies, as explained below for the specified businesses.

Overseas Realty (Ceylon) PLC

Pursuant to the agreement between the Company and the Board of Investment of Sri Lanka, the Company is entitled to a fifteen year "tax exemption period" on its accounting profits and income, commencing from the first year of making profit. The Company entered into a supplementary agreement with the Board

Notes to the Financial Statements

Year ended 31 December 2016

of Investment of Sri Lanka on 12 August 2005 with regard to the above.

The 15 year tax exemption period commenced in 2005 and will end in 2020 where business income is exempted and other income is taxable at normal rate. Thereafter Company will be taxed at 2% on turnover for another 15 years until 2035.

Mireka Capital Land (Private) Limited

Pursuant to the agreement with the Board of Investment of Sri Lanka (BOI) dated 28th April 2005, Mireka Capital Land (Private) Limited is exempted from income tax for a period of 8 years. Such exemption period is reckoned from the year in which the Company commences to make profit or any year of assessment not later than 2 years from the date of commencement of commercial operations, whichever is earlier, as may be specified in a certificate by BOI.

The 8 year tax exemption period commenced in 2006 and ended in 2014 where business income was exempted and other income was taxable at normal rate.

Mireka Homes (Private) Limited

Pursuant to the agreement with Board of Investment of Sri Lanka (BOI) dated 26th August 2005, Mireka Homes (Private) Limited is exempted from Income Tax for a period of 12 years. Such exemption period is reckoned from the year in which the Company commences to make profits or any year of assessment not later than 2 years from the date of commencement of commercial operations, whichever is earlier, as may be specified in a certificate by BOI.

The 12 year tax exemption period commenced in 2007 and will end on 2019. Income from sources falling outside the BOI approved business, is liable to income tax at 28%. Companies in the group other than specified above are also liable for income tax at 28%.

Deferred Taxation

Deferred income tax is provided, using the liability method, on temporary differences at the reporting date between the tax bases of assets and liabilities and their carrying amounts for financial reporting purposes.

Deferred income tax liabilities are recognised for all taxable temporary differences except where the deferred income tax liability arises from the initial recognition of an asset or liability in a transaction that is not a business combination and, at the time of the transaction, affects neither the accounting profit nor taxable profit or loss.

Deferred income tax assets are recognised for all deductible temporary differences, carry-forward of unused tax assets and unused tax losses, to the extent that it is probable that taxable profit will be available against which the deductible temporary differences, and the carry-forward of unused tax assets and unused tax losses can be utilised except where the deferred income tax asset relating to the deductible temporary difference arises from the initial recognition of an asset or liability in a transaction that is not a business combination and, at the time of the transaction, affects neither the accounting profit nor taxable profit or loss; and

The carrying amount of deferred income tax assets is reviewed at each balance sheet date and reduced to the extent that it is no longer probable that sufficient taxable profit will be available to allow all or part of the deferred income tax asset to be utilised.

Deferred income tax assets and liabilities are measured at the tax rates that are expected to apply to the year when the asset is realised or the liability is settled, based on tax rates (and tax laws) that have been enacted or substantively enacted at the reporting date.

Sales Tax

Revenues, expenses and assets are recognized net of the amount of sales tax except where the sales tax incurred on a purchase of assets or service is not recoverable from the taxation authorities in which case the sales tax is recognized as a part of the cost of the asset or part of the expense items as applicable and receivable and payable that are stated with the amount of sales tax included. The amount of sales tax recoverable and payable in respect of taxation authorities is included as a part of receivables and payables in the reporting date.

2.3.4 Borrowing Costs

Borrowing costs directly attributable to the acquisition or construction of an asset that necessarily takes a substantial period of time to get ready for its intended use or sale are capitalized as part of the cost of the respective assets. All other borrowing costs and borrowing costs incurred after the completion of the underlying construction are expensed in the period in which they occur. Borrowing costs consist of interest and other costs that an entity incurs in connection with the borrowing of funds.

The interest capitalized is calculated using Group's weighted average cost of borrowing after adjusting for borrowings associated with specific developments where, borrowings are associated with specific developments. Where borrowings are associated with developments, the amounts capitalized is the gross interest incurred on those borrowings less any investment income arising on their temporary investments. Interest is capitalized as from the commencement of the development work until date of practical completion. The capitalization of finance costs is suspended if there are prolonged periods when development activity is interrupted. Interest is also capitalized on the purchase cost of a site of property acquired specifically for development, but only where activities necessary to prepare the asset for redevelopments are in progress.

2.3.5 Revenue Recognition

Revenue is recognized to the extent that it is probable that the economic benefits will flow to the Group and the revenue can be reliably measured. Revenue is measured at the fair value of the consideration received or receivable net of trade discounts and sales taxes and value added tax.

a) Sale of Apartments

In the case of sale of apartments, the group has determined that equitable interest in the property has vested in the buyer before legal title passes, and the risks and rewards of ownership of such have been transferred at the time of entering into Sale and Purchase agreement. Therefore, revenue recognition from sale of apartments is begun from the point of entering in to Sale and Purchase Agreement. Where the property is under development for a considerable time frame and agreement has been reached to

sell such an apartment when construction works are completed, the directors consider whether the contract comprises;

- A contract to construct a property or
- A contract for the sale of a completed property

Where a contract is judged to be for the construction of a property, revenue is recognized using the percentage of completion method as construction of apartment's progresses.

Where the contract is for the sale of a completed property, revenue is recognised, when significant risk and returns have been transferred to the buyer, which is normally on unconditional exchange contracts.

b) Rental Income

Rental income receivable under operating leases is recognised on a straight-line basis over the term of the lease, except for contingent rental income which is recognised when it arises.

The lease term is the fixed period of the lease together with any further term for which the tenant has the option to continue the lease, where, at the inception of the lease, the Directors are reasonably certain that the tenant will exercise that option.

Premiums received to terminate leases are recognised in the Statement of Profit or Loss when they arise.

c) Rendering of Services

Revenue from rendering of services is recognized in the accounting period in which the services are rendered or performed.

d) Finance Income

Finance income is recognized as the interest accrues unless collectability is in doubt.

e) Others

Other income is recognized on an accrual basis.

Notes to the Financial Statements

Year ended 31 December 2016

2.3.6 Intangible Assets

(a) WTC Membership

Membership paid to World Trade Centers' Association (WTC Membership) is shown at historical cost. It is considered to have a finite useful life and carried at cost less accumulated amortization. Amortization is calculated using the straight-line method to allocate the cost over its estimated useful life of 20 years.

(b) Computer Software

Acquired computer software licenses are capitalized on the basis of the costs incurred to acquire and bring to use the specific software. These costs are amortized over their estimated useful life of 5 years. Costs associated with maintaining computer software programs are recognized as an expense as incurred.

(c) Goodwill

Goodwill is initially measured at cost. Following initial recognition, goodwill carried at cost less any accumulated impairment losses.

Gains or losses arising from de-recognition of an intangible asset are measured as the difference between the net disposal proceeds and the carrying amount of the asset and are recognized in the Statement of Profit or Loss when the asset is de-recognized.

2.3.7 Inventory

Work-in-Progress and Completed Apartments

Property acquired or being constructed for sale in the ordinary course of business, rather than to be held for rental or capital appreciation, and completed apartments are shown as inventories and measured at the lower of cost and net realizable value.

Cost includes:

- Freehold rights for land
- Amounts paid to contractors for construction
- Borrowing costs, planning and design costs, costs of site preparation, property transfer taxes, construction overheads and other related costs.

Non refundable commissions paid to sales or marketing agents on the sale of real estate units are expensed when paid.

Net realizable value is the estimated selling price in the ordinary course of the business, based on market prices at the reporting date and discounted for the time value of money if material, less costs to completion and the estimated costs of sale. The cost of inventory recognized in profit or loss on disposal is determined with reference to the costs incurred on the property sold and an allocation of costs based on the gross floor area of the property developed.

Work-in-progress that is intended to be completed within one year is classified as Current Inventories and those that take more than a year to complete are classified as Non-Current Inventories.

Consumables and Spares

Consumable and spares are stated at cost, accounted using at actual cost on weighted average basis.

2.3.8 Cash and Short-Term Deposits

Cash and cash equivalents are defined as cash in hand, demand deposits and short term highly liquid investments, readily convertible to known amounts of cash and subject to insignificant risk of changes in value.

For the purpose of cash flow statement, cash and cash equivalents consist of cash in hand and deposits in banks net of outstanding bank overdrafts. Investments with original maturities of three months or less are also treated as cash equivalents.

2.3.9 Property, Plant and Equipment

Property, plant and equipment except for buildings are stated at cost, excluding the costs of day to day servicing, less accumulated depreciation and accumulated impairment in value. Such cost includes the cost of replacing part of the property, plant and equipment when that cost is incurred, if the recognition criteria are met.

Buildings are measured at fair value less depreciation and impairment charged subsequent to the date of the revaluation.

The assets' residual values, useful lives and method of depreciation are reviewed, and adjusted if appropriate, at least at each financial year end. An asset's carrying amount is written down immediately to its recoverable amount if its carrying amount is greater than its estimated recoverable amount.

Valuations are performed with sufficient regularity, to ensure that the fair value of a revalued asset does not differ materially from its carrying amount.

When an item of property, plant & equipment is revalued, any accumulated depreciation at the date of the valuation is eliminated against the gross carrying amount of the asset and the net amount restated to the revalued amount of the asset.

Any revaluation surplus (related to property, plant & equipment) is credited to the revaluation reserve included in the equity section of the statement of financial position, except to the extent that it reverses a revaluation decrease of the same asset previously recognized in profit or loss. In which case, the increase is recognized in profit or loss. A revaluation deficit is recognized in profit or loss, except that a deficit directly offsetting a previous surplus on the same asset is directly offset against the surplus in the revaluation reserve.

Gains and losses on disposals are determined by comparing proceeds with carrying amount and are included in the Statement of Profit or Loss.

2.3.10 Financial Instruments — Initial Recognition and Subsequent Measurement

2.3.10.1 Financial Assets

The Group's financial assets include cash and short-term deposits, trade and other receivables, short term investments and amount due from related parties.

Initial Recognition and Measurement

Financial assets within the scope of LKAS 39 are classified as financial assets at fair value through profit or loss, loans and receivables, held-to-maturity investments, available-for-sale financial assets, or as derivatives designated as hedging instruments in an effective hedge, as appropriate. The Group

determines the classification of its financial assets at initial recognition.

All financial assets are recognised initially at fair value plus, in the case of assets not at fair value through profit or loss, directly attributable transaction costs.

Subsequent Measurement

The subsequent measurement of financial assets depends on their classification as follows:

a) Financial Assets at Fair Value through Profit or Loss

Financial assets at fair value through profit or loss include financial assets held for trading and financial assets designated upon initial recognition at fair value through profit or loss. Financial assets are classified as held for trading if they are acquired for the purpose of selling or repurchasing in the near term. This category includes derivative financial instruments entered into by the Group that are not designated as hedging instruments in hedge relationships as defined by LKAS 39. Derivatives, including separated embedded derivatives are also classified as held for trading unless they are designated as effective hedging instruments. Financial assets at fair value through profit and loss are carried in the statement of financial position at fair value with changes in fair value recognised in finance income or finance costs in the Statement of Profit or Loss.

The Group has not designated any financial assets upon initial recognition as at fair value through profit or loss.

The Group evaluates its financial assets held for trading, other than derivatives, to determine whether the intention to sell them in the near term is still appropriate. When the Group is unable to trade these financial assets due to inactive markets and management's intention to sell them in the foreseeable future significantly changes, the Group may elect to reclassify these financial assets in rare circumstances. The reclassification to loans and receivables, available-for-sale or held to maturity depends on the nature of the asset. This evaluation does not affect any financial assets designated at fair value through profit or loss using the fair value option at designation.

Notes to the Financial Statements

Year ended 31 December 2016

b) Loans and Receivables

Loans and receivables are non-derivative financial assets with fixed or determinable payments that are not quoted in an active market. After initial measurement, such financial assets are subsequently measured at amortised cost using the effective interest rate method (EIR), less impairment. Amortised cost is calculated by taking into account any discount or premium on acquisition and fees or costs that are an integral part of the EIR. The EIR amortisation is included in finance income in the Statement of Profit or Loss. The losses arising from impairment are recognised in the Statement of Profit or Loss in finance costs.

De-recognition

A financial asset is derecognised when:

- The rights to receive cash flows from the asset have expired
- The Group has transferred its rights to receive cash flows from the asset or has assumed an obligation to pay the received cash flows in full without material delay to a third party under a 'pass-through' arrangement; and either (a) the Group has transferred substantially all the risks and rewards of the asset, or (b) the Group has neither transferred nor retained substantially all the risks and rewards of the asset, but has transferred control of the asset.

When the Group has transferred its rights to receive cash flows from an asset or has entered into a pass-through arrangement, and has neither transferred nor retained substantially all of the risks and rewards of the asset nor transferred control of it, the asset is recognised to the extent of the Group's continuing involvement in it.

In that case, the Group also recognises an associated liability. The transferred asset and the associated liability are measured on a basis that reflects the rights and obligations that the Group has retained.

Continuing involvement that takes the form of a guarantee over the transferred asset is measured at the lower of the original carrying amount of the asset

and the maximum amount of consideration that the Group could be required to repay.

Impairment of Financial Assets

The Group assesses at each reporting date whether there is any objective evidence that a financial asset or a group of financial assets is impaired. A financial asset or a group of financial assets is deemed to be impaired if, and only if, there is objective evidence of impairment as a result of one or more events that has occurred after the initial recognition of the asset (an incurred 'loss event') and that loss event has an impact on the estimated future cash flows of the financial asset or the group of financial assets that can be reliably estimated. Evidence of impairment may include indications that the debtors or a group of debtors is experiencing significant financial difficulty, default or delinquency in interest or principal payments, the probability that they will enter bankruptcy or other financial reorganisation and where observable data indicate that there is a measurable decrease in the estimated future cash flows, such as changes in arrears or economic conditions that correlate with defaults.

Financial Assets carried at Amortized Cost

For financial assets carried at amortised cost, the Group first assesses whether objective evidence of impairment exists individually for financial assets that are individually significant, or collectively for financial assets that are not individually significant. If the Group determines that no objective evidence of impairment exists for an individually assessed financial asset, whether significant or not, it includes the asset in a group of financial assets with similar credit risk characteristics and collectively assesses them for impairment. Asset that are individually assessed for impairment and for which an impairment loss is, or continues to be, recognised are not included in a collective assessment of impairment.

If there is objective evidence that an impairment loss has been incurred, the amount of the loss is measured as the difference between the assets carrying amount and the present value of estimated future cash flows (excluding future expected credit losses that have not yet been incurred). The present value of the estimated

future cash flows are discounted at the financial asset's original effective interest rate. If a loan has a variable interest rate, the discount rate for measuring any impairment loss is the current effective interest rate.

The carrying amount of the asset is reduced through the use of an allowance account and the amount of the loss is recognised in the Statement of Profit or Loss. Interest income continues to be accrued on the reduced carrying amount and is accrued using the rate of interest used to discount the future cash flows for the purpose of measuring the impairment loss. The interest income is recorded as part of finance income in the Statement of Profit or Loss. Loans together with the associated allowance are written off when there is no realistic prospect of future recovery and all collateral has been realised or has been transferred to the Group. If, in a subsequent year, the amount of the estimated impairment loss increases or decreases because of an event occurring after the impairment was recognised; the previously recognised impairment loss is increased or reduced by adjusting the allowance account. If a future write-off is later recovered, the recovery is credited to finance costs in the Statement of Profit or Loss.

2.3.10.2 Financial Liabilities

The Group's financial liabilities include Trade and Other Payables, Dues to Related Parties, Rental and Customer Deposits and Interest Bearing Loans and Borrowings.

Initial Recognition and Measurement

Financial liabilities within the scope of LKAS 39 are classified as financial liabilities at fair value through profit or loss, loans and borrowings, or as derivatives designated as hedging instruments in an effective hedge, as appropriate. The Group determines the classification of its financial liabilities at initial recognition.

All financial liabilities are recognised initially at fair value and, in the case of loans and borrowings, carried at amortised cost. This includes directly attributable transaction costs. Any difference between initial fair value and the nominal amount is included as a

component of operating lease income and recognized on a straight line basis over the applicable time period.

Subsequent Measurement

The measurement of financial liabilities depends on their classification as follows:

Loans and Borrowings

After initial recognition, interest bearing loans and borrowings are subsequently measured at amortised cost using the effective interest rate method. Gains and losses are recognised in the Statement of Profit or Loss when the liabilities are derecognised as well as through the effective interest rate method (EIR) amortisation process.

Amortised cost is calculated by taking into account any discount or premium on acquisition and fees or costs those are an integral part of the EIR. The EIR amortisation is included in finance costs in the Statement of Profit or Loss.

De-recognition

A financial liability is derecognised when the obligation under the liability is discharged or cancelled or expires. When an existing financial liability is replaced by another from the same lender on substantially different terms, or the terms of an existing liability are substantially modified, such an exchange or modification is treated as a de-recognition of the original liability and the recognition of a new liability, and the difference in the respective carrying amounts is recognised in the Statement of Profit or Loss.

2.3.10.3 Fair Value Measurement

Fair value is the price that would be received to sell an asset or paid to transfer a liability in an orderly transaction between market participants at the measurement date. The fair value measurement is based on the presumption that the transaction to sell the asset or transfer the liability takes place either:

- In the principal market for the asset or liability
- **Or**
- In the absence of a principal market, in the most advantageous market for the asset or liability

Notes to the Financial Statements

Year ended 31 December 2016

The principal or the most advantageous market must be accessible by the Group.

The fair value of an asset or a liability is measured using the assumptions that market participants would use when pricing the asset or liability, assuming that market participants act in their economic best interest.

A fair value measurement of a non-financial asset takes into account a market participant's ability to generate economic benefits by using the asset in its highest and best use or by selling it to another market participant that would use the asset in its highest and best use.

The Group uses valuation techniques that are appropriate in the circumstances and for which sufficient data are available to measure fair value, maximising the use of relevant observable inputs and minimising the use of unobservable inputs.

All assets and liabilities for which fair value is measured or disclosed in the financial statements are categorised within the fair value hierarchy, described as follows, based on the lowest level input that is significant to the fair value measurement as a whole:

- Level 1 - Quoted (unadjusted) market prices in active markets for identical assets or liabilities
- Level 2 - Valuation techniques for which the lowest level input that is significant to the fair value measurement is directly or indirectly observable
- Level 3 - Valuation techniques for which the lowest level input that is significant to the fair value measurement is unobservable for the purpose of fair value disclosures, the group has determined classes of assets and liabilities on the basis of the nature, characteristics and risks of the asset or liability and the level of the fair value hierarchy as explained above.

For assets and liabilities that are recognised in the financial statements on a recurring basis, the Group determines whether transfers have occurred between levels in the hierarchy by re-assessing categorization (based on the lowest level input that is significant to the fair value measurement as a whole) at the end of each reporting period.

The Management of the Group determines the policies and procedures for both recurring fair value measurement, such as investment properties and Property, Plant and Equipment-Buildings.

External valuer, Mr. P.B Kalugalgedara is involved in valuation of significant assets, such as Investment properties and Buildings.

Involvement of external valuers is decided upon annually by the Management after discussion with and approval by the Company's Audit Committee. Selection criteria include market knowledge, reputation, independence and whether professional standards are maintained. The Management, after discussions with the Group's external valuer, which valuation techniques and inputs to use for each case.

At each reporting date, the Management analyses the movements in the values of assets which are required to be re-measured or re-assessed as per the Group's accounting policies. For this analysis, the Management verifies the major inputs applied in the latest valuation by agreeing the information in the valuation computation to contracts and other relevant documents.

The Management, in conjunction with the Group's external valuer, also compares the change in the fair value of each asset with relevant external sources to determine whether the change is reasonable.

For the purpose of fair value disclosures, the Group has determined classes of assets and liabilities on the basis of the nature, characteristics and risks of the asset or liability and the level of the fair value hierarchy as explained above.

2.3.11 Investments

a) Investment in Subsidiaries

Investments are stated at cost in the company's financial Statements. Carrying amounts are reduced to recognize a decline other than temporary, determined for each investment individually. These reductions for other than temporary declines in carrying amounts are charged to the Statement of Profit or Loss.

2.3.12 Investment Property

Property that is held for long term rental yields or for capital appreciation or both and that is not occupied by the entities in the Group is classified as Investment Property.

Investment Property comprises freehold land, freehold buildings together with the integral parts of such properties.

Investment Property is measured initially at its cost, including related transaction costs. After initial recognition, Investment Property is carried at fair value.

The fair value of Investment Property reflects, among other things, rental income from current leases and assumptions about rental income from future leases in the light of current market conditions, as appraised by an independent valuer, annually.

Subsequent expenditure is charged to the asset's carrying amount only when it is probable that future economic benefits associated with the item will flow to the Group and the cost of the item can be measured reliably. All other repairs and maintenance costs are charged to the Statement of Profit or Loss during the financial period in which they are incurred.

Gains or losses arising from changes in the fair values of investment properties are included in the profit or loss in the period in which they arise. Fair values are determined based on an annual evaluation performed by an accredited external independent valuer applying a valuation model recommended by the International Valuation Standards Committee.

If an Investment Property becomes owner occupied, it is reclassified as Property, Plant and Equipment and its fair value at the date of reclassification becomes its cost for accounting purposes. Property that is being constructed or developed for future use as Investment Property is classified as property, plant and equipment and stated at cost until construction or development is complete. At that time, it is reclassified and subsequently accounted for as Investment Property.

2.3.13 Provisions

Provisions are recognized when the Group has a present obligation (legal or constructive) as a result of a past event, where it is probable that an outflow of resources embodying economic benefits will be required to settle the obligation and a reliable estimate can be made of the amount of the obligation. When the Group expects some or all of a provision to be reimbursed, the reimbursement is recognized as a separate asset but only when the reimbursement is virtually certain. The expense relating to any provision is presented in the Statement of Profit or Loss net of any reimbursement. If the effect of the time value of money is material, provisions are determined by discounting the expected future cash flows at a pre-tax rate that reflects current market assessments of the time value of money and where appropriate, the risks specific to the liability. Where discounting is used, the increase in the provision due to the passage of time is recognized as an interest expense.

2.3.14 Retirement Benefit Obligations

a) Defined Benefit Plan – Gratuity

The Group is liable to pay gratuity in terms of the Gratuity Act No.12 of 1983.

The Group measures the present value of the promised retirement benefits of gratuity, which is a defined benefit plan with the advice of an independent actuary.

For the purpose of determining the charge for any period before the next regular actuarial valuation falls due, an approximate estimation provided by the qualified actuary is used.

The cost of providing benefits under the defined benefit plan is determined using the projected unit credit method. Re-measurements, comprising of actuarial gains and losses, excluding net interest (not applicable to the Group) and the return on plan assets (excluding net interest), are recognized immediately in the statement of financial position with a corresponding debit or credit to retained earnings through Other Comprehensive Income in the period in which they occur. Re-measurements are not reclassified to profit or loss in subsequent periods.

Notes to the Financial Statements

Year ended 31 December 2016

Past service costs are recognised in profit or loss on the earlier of:

- The date of the plan amendment or curtailment, and
- The date that the Group recognises restructuring-related costs

Net interest is calculated by applying the discount rate to the net defined benefit liability. The Group recognises the following changes in the net defined benefit obligation under 'cost of sales' and 'administration expenses' in the Statement of Profit or Loss:

- Service costs comprising current service costs, past-service costs, gains and losses on curtailments and non-routine settlements
- Net interest expense or income

The gratuity liability is not externally funded. This item is stated under Post Employee Benefit Liability in the Statement of Financial Position.

b) Defined Contribution Plans – Employees' Provident Fund & Employees' Trust Fund

Employees are eligible for Employees' Provident Fund Contributions and Employees' Trust Fund Contributions in line with the respective statutes and regulations. The Group contributes 12% and 3% of gross emoluments of employees to Employees' Provident Fund and Employees' Trust Fund respectively.

2.3.15 Impairment of Non Financial Assets

The Group assesses at each reporting date whether there is an indication that an asset may be impaired. If any such indication exists, or when annual impairment testing for an asset is required, the Group makes an estimate of the asset's recoverable amount. An asset's recoverable amount is the higher of an asset's or cash-generating unit's fair value less costs to sell and its value in use and is determined for an individual asset, unless the asset does not generate cash inflows that are largely independent of those from other assets or groups of assets. Where the carrying

amount of an asset exceeds its recoverable amount, the asset is considered impaired and is written down to its recoverable amount. In assessing value in use, the estimated future cash flows are discounted to their present value using a pre-tax discount rate that reflects current market assessments of the time value of money and the risks specific to the asset. In determining fair value less costs to sell, an appropriate valuation model is used. These calculations are corroborated by valuation multiples or other available fair value indicators.

Impairment losses of continuing operations are recognised in the Statement of Profit or Loss in those expense categories consistent with the function of the impaired asset, except for property previously revalued where the revaluation was taken to equity. In this case the impairment is also recognised in equity up to the amount of any previous revaluation.

For assets, an assessment is made at each reporting date as to whether there is any indication that previously recognized impairment losses may no longer exist or may have decreased. If such indication exists, the Group makes an estimate of the recoverable amount. A previously recognized impairment loss is reversed only if there has been a change in the estimates used to determine the asset's recoverable amount since the last impairment loss was recognized. If that is the case the carrying amount of the asset is increased to its recoverable amount. That increased amount cannot exceed the carrying amount that would have been determined, net of depreciation, had no impairment loss been recognized for the asset in prior years. Such reversal is recognized in the Statement of Profit or Loss unless the asset is carried at revalued amount, in which case the reversal is treated as a revaluation increase.

2.3.16 Super Gain Tax (SGT)

As per the provisions of Part III of the Finance Act, No. 10 of 2015 which was certified on 30 October 2015, the Group was liable for Super Gain tax of Rs. 49 Million (Company; 43 Million). According to the Act, the super gain tax shall be deemed to be an expenditure in the financial statements relating to the year of assessment which commenced on 1 April

2013. The expense of Super gain tax is accounted in accordance with the requirements of the said Act as recommended by the Statement of Alternative Treatment (SoAT) on Accounting for Super Gain Tax issued by the Institute of Chartered Accountants of Sri Lanka, dated 24 November 2015.

2.4 EFFECT OF SRI LANKA ACCOUNTING STANDARDS (SLFRS) ISSUED BUT NOT YET EFFECTIVE:

A number of new standards and amendments to standards are effective for annual periods beginning after 1 January 2016 and earlier application is permitted; however, the Company/ Group has not early adopted the following new or amended standards in preparing these consolidated financial statements.

SLFRS 9 Financial Instruments

SLFRS 9 replaces the existing guidance in LKAS 39 Financial Instruments: Recognition and Measurement. SLFRS 9 includes revised guidance on the classification and measurement of financial instruments, a new expected credit loss model for calculating impairment on financial assets, and new general hedge accounting requirements. It also carries forward the guidance on recognition and derecognition of financial instruments from LKAS 39.

SLFRS 9 is effective for annual reporting periods beginning on or after 1 January 2018, with early adoption permitted.

SLFRS 15 Revenue from Contracts with Customers

SLFRS 15 establishes a comprehensive framework for determining whether, how much and when revenue is recognized. It replaces existing revenue recognition guidance, including LKAS 18 Revenue, LKAS 11 Construction Contracts and IFRIC 13 Customer Loyalty Programmes.

SLFRS 15 is effective for annual reporting periods beginning on or after 1 January 2018, with early adoption permitted.

SLFRS 16 Leases

SLFRS 16 provides a single lessee accounting model, requiring leases to recognise assets and liabilities for

all leases unless the lease term is 12 months or less or the underlying asset has a low value even though lessor accounting remains similar to current practice. This supersedes: LKAS 17 Leases, IFRIC 4 determining whether an arrangement contains a Lease, SIC 15 Operating Leases- Incentives; and SIC 27 Evaluating the substance of Transactions Involving the Legal form of a Lease. Earlier application is permitted for entities that apply SLFRS 15 Revenue from Contracts with customers.

SLFRS 16 is effective for annual reporting periods beginning on or after 1 January 2019.

Management believes that the SLFRS 9 would not have significant impact to the financial statements of the Company due to their business model. The preliminary evaluation of impact analysis of SLFRS 15 and 16 carried out by the management reveals that there will not be a significant change to the current practice. However, the Management is in the process of evaluating and quantifying the accounting impact.

The following amendments and improvements are not expected to have a significant impact on the Company's/ Group's consolidated financial statements.

- Amendments to SLFRS 10 and LKAS 28: Sale or Contribution of Assets between an Investor and its Associate
- LKAS 7 Disclosure Initiative – Amendments to LKAS 7
- LKAS 12 Recognition of Deferred Tax Assets for Unrealised Losses – Amendments to LKAS 12
- SLFRS 2 Classification and Measurement of Share-based Payment Transactions — Amendments to SLFRS 2
- Applying SLFRS 9 Financial Instruments with SLFRS 4 Insurance Contracts — Amendments to SLFRS 4

Notes to the Financial Statements

Year ended 31 December 2016

3. SEGMENTAL INFORMATION

The Group has three business segments, Property Leasing, Property Services and Property Trading. Property Leasing is derived by Overseas Realty (Ceylon) PLC (ORC PLC) and SK Investments Lanka (Private) Limited (SKIL), Property Services is derived by ORC PLC, SKIL and Realty Management Services (Pvt) Ltd (RMS) and Property Trading is derived through Mireka Capital Land (Pvt) Ltd (MCL) and Mireka Homes (Pvt) Ltd (MHL). ORC PLC and SKIL earns rental income by way of renting out the space at "World Trade Center" located at Echelon Square, Colombo 1. while Realty Management Services (Pvt) Ltd (RMS) is engaged in brokering, providing absentee landlord management, providing facility management and related services and trading lighting solutions. MCL recognises revenue through the sale of land and infrastructure and MHL recognises revenue through the sale of condominium units of "Havelock City".

Management monitors the operating results of its business segments separately for the purpose of making decisions about resource allocation and performance assessment.

3.1 Segment Results :

	2016				2015					
	Property Leasing	Property Services	Property Trading	Inter/Intra Segment Eliminations	Consolidated 2016	Property Services	Property Trading	Inter/Intra Segment Eliminations	Consolidated 2015	
	Rs.	Rs.	Rs.	Rs.	Rs.	Rs.	Rs.	Rs.	Rs.	
Revenue	1,886,277,287	-	285,146,935	-	2,171,424,221	1,962,481,494	-	859,264,842	114,321,097	2,936,067,433
Other Services	47,696,512	224,846,041	-	(13,233,756)	259,308,797	46,488,998	167,210,197	-	(9,100,517)	204,598,678
Total Revenue	1,933,973,799	224,846,041	285,146,935	(13,233,756)	2,430,733,019	2,008,970,492	167,210,197	859,264,842	105,220,580	3,140,666,111
Direct Operating Expenses	(436,497,444)	(178,554,588)	-	-	(615,052,032)	(421,437,467)	(126,919,414)	-	-	(548,356,881)
Cost of Sales	-	-	(159,685,351)	-	(159,685,351)	-	-	(652,623,361)	-	(652,623,361)
Gross Profit/ (Loss)	1,497,476,355	46,291,453	125,461,584	(13,233,756)	1,655,995,636	1,587,533,025	40,290,783	206,641,481	105,220,580	1,939,685,869
Fair Value Gain on Investment Property	1,267,315,858	-	-	-	1,267,315,858	1,174,538,190	-	-	-	1,174,538,190
Administration Expenses	(176,444,460)	(24,901,064)	(66,207,054)	-	(267,552,578)	(162,054,729)	(19,921,650)	(84,198,316)	779,799	(265,394,896)
Marketing and Promotional Expenses	-	-	(55,411,940)	-	(55,411,940)	-	-	(39,105,751)	-	(39,105,751)
Exchange Gain/(Loss)	3,988,262	-	7,043,842	-	11,032,104	5,887,498	-	3,777,292	-	9,664,790
Finance Cost	(45,134,290)	-	(9,442,603)	-	(54,576,893)	(5,140,030)	-	(7,199,241)	-	(12,339,271)
Finance Income	306,560,916	1,882,380	23,343,206	-	331,786,502	173,298,077	549,828	7,725,053	-	181,572,958
Other Income	110,453,429	-	33,106,915	(58,295,704)	85,264,640	115,959,244	-	24,680,137	(56,350,200)	84,289,181
Net Profit Before Tax	2,964,216,069	23,272,769	57,893,950	(71,529,460)	2,973,853,329	2,890,021,275	20,918,961	112,320,654	49,650,179	3,072,911,070

Notes to the Financial Statements

Year ended 31 December 2016

5. INVESTMENT PROPERTY

	Group		Company	
	2016 Rs.	2015 Rs.	2016 Rs.	2015 Rs.
As at 1 January	22,579,410,997	21,404,872,807	22,579,410,997	21,404,872,807
Acquisition of Subsidiary (Note 8.2)	805,044,000	-	-	-
Net Gain from Fair Value Adjustment	1,267,315,858	1,174,538,190	1,261,287,858	1,174,538,190
As at 31 December	24,651,770,855	22,579,410,997	23,840,698,855	22,579,410,997

- 5.1 The Company filed a Deed of Declaration No. 237 dated 27 June 2001 attested by Ms. A. R. Edirimane, Notary Public, sub dividing the Company's property, (i.e. World Trade Center at Echelon Square) into 219 condominium units in accordance with the Condominium Plan No. 1824 dated 25 April 2001 made by Mr. M.T. Rathnayake, Licensed Surveyor of Survey Engineering Co. Limited. The Urban Development Authority approved such plan under Section 594 (b) and 5(2) of the Apartment Ownership Law No.11 of 1973 as amended by Act No. 45 of 1982, on 14 June 2001.

The said Condominium Plan and Deed of Declaration were registered with the Land Registry on 04 July 2001, thus resulting in the creation of the "Management Corporation Condominium Plan No. 1824" under the provisions of the Apartment Ownership Law.

- 5.2 The Company owns 185 Condominium Units that are held to earn rentals. These units constitute the Investment Property of the Group.

Fair value of the Investment Property is ascertained annually by independent valuations carried out by Mr. P.B. Kalugalagedera, Chartered Valuation Surveyor that has recent experience in valuing properties of akin location and category. Investment Property was appraised in accordance with Sri Lanka Accounting Standards and 8th edition of International Valuation Standards published by the International Valuation Standards Committee (IVSC), by the independent valuer. In determining the fair value, the capitalization of net income method and the discounting of future cash flows to their present value have been used which are based upon assumptions including future rental income, anticipated maintenance costs, appropriate discount rate and making reference to market evidence of transaction prices for similar properties, with appropriate adjustments for size and location. The appraised fair values are approximated within appropriate range of values.

The significant assumptions used by the valuer in the years 2015 and 2016 are as follows:

Significant Unobservable Inputs	Valuation Technique	2016	2015
Estimated Market Rent per sq:ft	Investment Method (Income Approach) using the discounted cash flows	: Rs.275-325	: Rs.240-285
Rate of Growth in Future Rentals		: 1 to 2 years 0% : 3-10 years 5% p.a.	: 1 to 2 years 0% : 3-10 years 5% p.a.
Anticipated Maintenance Cost		: 45% of rentals	: 45% of rentals
Capitalization Rate		: 6% p.a.	: 5.75% p.a.

5.3 Sensitivity Analysis of Assumptions Employed in Investment Property Valuation

Group

The table below presents the sensitivity of the valuation to changes in the most significant assumptions underlying the valuation of Investment Property, in respect of the year 2016.

The sensitivity of the Income Statement and Statement of Financial Position is the effect of the assumed changes in discount rate, growth rate and rate of maintenance cost (taken individually, while other variables are held constant) on the profit or loss and carrying value of Investment Property for the year.

Capitalization Rate	Increase / (Decrease)		Preforma Investment Property valuation Rs.	Effect on Fair Value Gain/ (Loss) on Investment Property Rs.
	Growth in Future Rentals (3-10 Years)	Anticipated Maintenance Cost		
1%			20,885,213,260	(3,766,557,595)
-1%			29,949,718,123	5,297,947,268
	1%		26,170,624,373	1,518,853,518
	-1%		23,230,310,024	(1,421,460,831)
		5%	22,390,816,958	(2,260,953,897)
		-5%	25,516,889,887	2,260,953,897

Company

Capitalization Rate	Increase / (Decrease)		Preforma Investment Property valuation Rs.	Effect on Fair Value Gain/ (Loss) on Investment Property Rs.
	Growth in Future Rentals (3-10 Years)	Anticipated Maintenance Cost		
1%			20,198,750,885	(3,641,947,970)
-1%			28,963,306,288	5,122,607,433
	1%		25,306,300,683	1,465,601,828
	-1%		22,463,194,811	(1,377,504,044)
		5%	21,653,478,777	(2,187,220,078)
		-5%	24,632,084,069	2,187,220,078

5.4 The Group and Company use unobservable market inputs in determining the fair value of the Investment Property (i.e. Falling under Level 3 of the fair value hierarchy)

5.5 Rental Income earned and Direct operating expenses relating to Investment Property is tabulated below:

	Group (Rs. Mn)		Company (Rs. Mn)	
	2016	2015	2016	2015
Rental income	1,886	1,962	1,859	1,962
Direct operating expenses	436	421	423	421

Notes to the Financial Statements

Year ended 31 December 2016

6. PROPERTY, PLANT AND EQUIPMENT

6.1 GROUP

6.1.1 Gross Carrying Amounts

	At Cost					At Valuation			Total Gross Carrying Amount
	Land Rs.	Temporary Building Rs.	Equipment Rs.	Computer and Electronic Equipment Rs.	Furniture and Fittings Rs.	Motor Vehicles Rs.	Buildings Rs.	In the Course of Construction Rs.	
At Cost or Valuation									
Balance as at 1 January 2016	-	6,488,324	19,256,594	36,781,594	32,611,693	27,607,834	1,062,741,472	490,120,498	1,675,608,009
Additions during the Year	-	-	579,051	4,946,323	3,391,828	-	-	71,697,932	80,615,134
Disposals during the Year	-	-	(354,000)	-	-	-	-	-	(354,000)
Transfers from Inventory	86,144,695	-	-	-	-	-	-	-	86,144,695
Transfers*	-	-	-	-	-	-	(20,995,909)	-	(20,995,909)
Revaluations	-	-	-	-	-	-	50,708,051	-	50,708,051
Balance as at 31 December 2016	86,144,695	6,488,324	19,481,645	41,727,917	36,003,521	27,607,834	1,092,453,614	561,818,430	1,871,725,980

6.1.2 Depreciation

	At Cost					At Valuation			Total Gross Carrying Amount
	Land Rs.	Temporary Building Rs.	Equipment Rs.	Computer and Electronic Equipment Rs.	Furniture and Fittings Rs.	Motor Vehicles Rs.	Buildings Rs.	In the Course of Construction Rs.	
At Cost or Valuation									
Balance as at 1 January 2016	-	4,846,446	10,204,095	30,571,818	23,431,717	8,448,526	-	-	77,502,603
Charged for the Year	-	1,300,504	2,143,742	2,776,944	2,051,557	4,277,384	20,995,909	-	33,546,040
Disposals during the Year	-	-	(354,000)	-	-	-	-	-	(354,000)
Transfers*	-	-	-	-	-	-	(20,995,909)	-	(20,995,909)
Balance as at 31 December 2016	-	6,146,950	11,993,837	33,348,762	25,483,274	12,725,910	-	-	89,698,733

6.1.3 Net Book Value

	2016	2015
	Rs.	Rs.
At Cost		
Land	86,144,695	-
Temporary Building	341,374	1,641,878
Equipment	7,487,808	9,052,499
Computers and Electronic Equipment	8,379,155	6,209,776
Furniture and Fittings	10,520,247	9,179,975
Motor Vehicles	14,881,924	19,159,308
	127,755,204	45,243,436
At Valuation		
Buildings	1,092,453,614	1,062,741,472
	1,092,453,614	1,062,741,472
In the Course of Construction		
Capital Work In Progress	561,818,430	490,120,498
	561,818,430	490,120,498
	1,782,027,248	1,598,105,407

* This transfer relates to the accumulated depreciation as at the revaluation date that was eliminated against the gross carrying amount of the revalued asset.

Notes to the Financial Statements

Year ended 31 December 2016

6 PROPERTY, PLANT AND EQUIPMENT (Contd.)

6.2 COMPANY

6.2.1 Gross Carrying Amounts

	At Cost				At Valuation				Total Gross Carrying Amount Rs.
	Equipment Rs.	Computers and Electronic Equipment Rs.	Furniture and Fittings Rs.	Motor Vehicles Rs.	Buildings Rs.	In the Course of Construction Rs.			
Balance as at 1 January 2016	5,963,833	26,070,864	20,575,790	27,365,834	336,589,004	2,304,921		418,870,246	
Additions during the Year	451,701	3,155,913	244,767	-	-	-		3,852,381	
Revaluation	-	-	-	-	36,185,002	-		36,185,002	
Transfers*	-	-	-	-	(6,472,860)	-		(6,472,860)	
Balance as at 31 December 2016	6,415,534	29,226,777	20,820,557	27,365,834	366,301,146	2,304,921		452,434,769	

6.2.2 Depreciation

	At Cost				At Valuation				Total Gross Carrying Amount Rs.
	Equipment Rs.	Computers and Electronic Equipment Rs.	Furniture and Fittings Rs.	Motor Vehicles Rs.	Buildings Rs.	In the Course of Construction Rs.			
Balance as at 1 January 2016	4,606,312	23,189,428	18,933,115	8,206,526	-	-		54,935,381	
Charged for the Year	272,990	1,164,427	498,708	4,277,384	6,472,860	-		12,686,369	
Transfers*	-	-	-	-	(6,472,860)	-		(6,472,860)	
Balance as at 31 December 2016	4,879,302	24,353,855	19,431,823	12,483,910	-	-		61,148,890	

* This transfer relates to the accumulated depreciation as at the revaluation date that was eliminated against the gross carrying amount of the revalued asset.

6.2.3 Net Book Value

	2016	2015
	Rs.	Rs.
At Cost		
Equipment	1,536,232	1,357,521
Computers and Electronic Equipment	4,872,922	2,881,436
Furniture and Fittings	1,388,734	1,642,675
Motor Vehicles	14,881,924	19,159,308
	22,679,812	25,040,940
At Valuation		
Buildings	366,301,146	336,589,004
	366,301,146	336,589,004
In the Course of Construction		
Capital Work In Progress	2,304,921	2,304,921
	2,304,921	2,304,921
	391,285,879	363,934,865

- 6.3** The fair value of building (Level 18 of the World Trade Centre held as owner occupied property) was determined by means of a revaluation during the financial year 2016 by Mr. P.B. Kalugalagedera, an independent valuer. The results of such revaluation were incorporated in these Financial Statements from its effective date which is 31 December 2016. The surplus arising from the revaluation was transferred to a revaluation reserve. The valuation that was used to ascertain the value of investment property was used for the determination of the fair value of the Buildings-Level 18 carried at fair value. Further, similar assumptions have been used in determining the fair value of the property as given in Note 5.2.
- 6.4** The fair value of building (Club House at Havelock City) was determined by means of a revaluation using the replacement cost approach during the financial year 2016 by Mr. P.B. Kalugalagedera, an independent valuer. The results of such revaluation were incorporated in these Financial Statements from its effective date which is 31 December 2016.
- 6.5** Cash payments amounting to Rs.80,615,134/- (2015 : Rs. 35,939,895/-) were made during the year by the Group and Rs.3,852,381/- (2015 : Rs. 16,557,912/-) were made by the Company for purchase of Property, Plant and Equipment.
- 6.6** Depreciation is calculated on a straight line basis over the useful life of the assets as follows :
- | | |
|-----------------------------------|-------------------|
| Buildings | Over 60 Years |
| Temporary Building | Over 5 Years |
| Computer and Electronic Equipment | Over 4 Years |
| Equipment | Over 5 - 10 Years |
| Furniture & Fittings | Over 10 Years |
| Motor Vehicles | Over 5 Years |
- 6.7** No depreciation for the year 2016 and 2015 has been transferred to Inventory/Project Under Development during the year by the Group.
- 6.8** Property, Plant and Equipment of the Group and the Company includes fully depreciated assets having a gross carrying amount of Rs.57,459,654/- and Rs. 48,197,482/- (2015 : Rs. 55,255,463 and Rs.47,111,952 /-) respectively. Those assets are still in use for supply of services and administrative purpose.

Notes to the Financial Statements

Year ended 31 December 2016

6 PROPERTY, PLANT AND EQUIPMENT (Contd.)

6.9 The carrying amount of revalued assets that would have been included in the Financial Statements had the assets been carried at cost less depreciation is as follows:

Class of Asset	Cost	Cumulative Depreciation If assets were carried at cost	Net Carrying Amount 2016	Net Carrying Amount 2015
	Rs.	Rs.	Rs.	Rs.
Group				
Building - Level 18	87,431,566	(19,587,596)	67,843,970	74,316,830
Building - Club House	726,671,879	(29,056,484)	697,615,395	712,138,441
	814,103,445	(48,644,080)	765,459,365	786,455,271

6.10 The Group and Company use unobservable market inputs in determining the fair value of the buildings reflected at its fair value (i.e. falling under Level 3 of the fair value hierarchy)

7. INTANGIBLE ASSETS

7.1 Group

	WTC Membership Rs.	Computer Software Rs.	Goodwill Rs.	Total Rs.
Summary	(Note 7.3)	(Note 7.4)	(Note 7.5)	
Cost				
As at 1 January 2016	7,297,734	28,919,768	8,794,864	45,012,366
Acquired / Incurred during the Year	-	-	-	-
As at 31 December 2016	7,297,734	28,919,768	8,794,864	45,012,366
Amortization				
As at 1 January 2016	7,297,734	25,385,446	-	32,683,180
Amortization /write-off made during the Year	-	1,470,252	8,794,864	10,265,116
As at 31 December 2016	7,297,734	26,855,698	8,794,864	42,948,296
Net book value				
As at 1 January 2016	-	3,534,322	8,794,864	12,329,186
As at 31 December 2016	-	2,064,070	-	2,064,070

7.2 Company

	WTC Membership Rs.	Computer Software Rs.	Total Rs.
Summary	(Note 7.3)	(Note 7.4)	
Cost			
As at 1 January 2016	7,297,734	28,919,768	36,217,502
Acquired / Incurred during the Year	-	-	-
As at 31 December 2016	7,297,734	28,919,768	36,217,502
Amortization			
As at 1 January 2016	7,297,734	25,385,446	32,683,180
Amortization for the Year	-	1,470,252	1,470,252
As at 31 December 2016	7,297,734	26,855,698	34,153,432
Net book value			
As at 1 January 2016	-	3,534,322	3,534,322
As at 31 December 2016	-	2,064,070	2,064,070

7.3 WTC membership fee represent the original amount paid to be eligible to use the trade name "World Trade Centre".

7.4 Computer software represent the Enterprise Resource Planning System (ERP) consisting of application software, user license and implementation services of which the management of the Company has determined the useful life as five (5) years. Amortization has been made on a straight line basis in the Income Statement. During the year 2016 and 2015 no investment made in the ERP system.

7.5 Goodwill is related to the acquisition of Mireka Capital Land (Pvt) Ltd, this amount was write-off during the year.

8. INVESTMENTS IN SUBSIDIARIES

	Holding %	Group		Company	
		2016 Rs.	2015 Rs.	2016 Rs.	2015 Rs.
Non-Quoted Investment at cost					
Mireka Capital Land (Pvt) Ltd.	100%	-	-	5,005,000,000	1,125,000,000
Hospitality International (Pvt) Ltd.	100%	-	-	112,159,107	112,159,107
Realty Management Services (Pvt) Ltd.	100%	-	-	10,020	10,020
Property Mart (Pvt) Ltd.	100%	-	-	20	20
SK Investments Lanka (Pvt) Ltd	100%	-	-	763,524,604	
		-	-	5,880,693,751	1,237,169,147
Provision for Impairment: Hospitality International (Pvt) Ltd.		-	-	(112,159,107)	(112,159,107)
		-	-	5,768,534,644	1,125,010,040

Notes to the Financial Statements

Year ended 31 December 2016

8 INVESTMENTS IN SUBSIDIARIES (Contd.)

8.1 All subsidiaries are incorporated in Sri Lanka.

8.2 Acquisitions in 2016

Overseas Realty (Ceylon) PLC acquired 100% of voting shares of SK investments Lanka (Private) Limited (SKIL) on 26 of April 2016 from Shing Kwan Investment (Singapore) Pte Ltd. This transaction was accounted as business combination of entities under common control by using pooling of interest method.

The carrying value of identifiable assets and liabilities of SKIL as of 26 April 2016 were;

	Carrying value recognised on acquisition Rs.
Investment property (Note 5)	805,044,000
Trade and other receivables	2,560,108
Income Tax receivables	377,335
Cash and Cash Equivalents	32,485,085
Total Assets	840,466,528
Deferred tax liabilities (Note 9)	61,700,350
Rental Deposits (Note 18)	11,860,791
Trade and other payables	3,836,257
	77,397,398
Total identifiable net assets at carrying amount*	763,069,130
	Cashflow on acquisition Rs.
Net cash acquired with the Subsidiary	32,485,085
Cash paid	(74,552,141)
	(42,067,056)

*This amount consists of cash paid of Rs. 75 Mn and acquisition debt of Rs. 688 Mn. Subsequent to financial year end, the acquired debt was settled by the Company.

8.3 Acquisition of additional interest in Mireka Capital Land (Pvt) Ltd

On 30th December 2016 the Company increased its Shareholding in Mireka Capital Land (Pvt) Ltd, (MCL) from 60% to 100% by purchasing the balance 40% shareholding in MCL at a total consideration of Rs 3.880 Billion. The Company has also undertaken to pay the seller up to a maximum of Rs 243.2 Million, being 40% of the value of any favorable outcome or benefit, which may accrue to the MCL Group in relation to its Contingent Liabilities.

	Rs.
Cash consideration paid to Non controlling interest	3,880,000,000
Carrying value of the additional interest in MCL	(1,497,400,063)
Difference recognised in retained earnings	2,382,599,937

9. DEFERRED TAX

9.1 Group

	Statement of Financial Position		Statement of Profit or Loss	
	2016	2015	2016	2015
	Rs.	Rs.	Rs.	Rs.
Deferred Tax Assets Arising on:				
Unused Carried Forward Tax Losses	146,230,041	26,179,412	120,050,629	2,529,179
Post Employment Benefit Liability	2,729,159	2,951,162	(222,004)	(103,604)
Property Plant and Equipment	291,975	233,580	58,395	(231,814)
	149,251,175	29,364,154	119,887,021	2,193,761
Deferred Tax Liability Arising on:				
Investment Property	(98,840,701)	-	(98,840,701)	
Property Plant and Equipment	(127,488,502)	(22,708,034)	(104,780,468)	(22,708,034)
	(226,329,203)	(22,708,034)	(203,621,169)	(22,708,034)
Deferred Tax Expense/(Income)			(83,734,148)	(20,514,273)
Net Deferred Tax Asset/(Liability)	(77,078,028)	6,656,120		

Reflected in the Statement of Financial Position as follows:

	2016	2015
	Rs.	Rs.
Balance brought forward	(6,656,120)	(27,170,393)
Acquisition of Subsidiary (Note 8.2)	61,700,350	-
Deferred Income Tax (Credit)/Charge-Statement of Profit or Loss	20,190,283	17,467,354
Deferred Income Tax (Credit)/Charge- Statement of Comprehensive Income	1,843,516	3,046,919
Net Deferred Tax (Asset)/Liability	77,078,029	(6,656,120)

Notes to the Financial Statements

Year ended 31 December 2016

9. DEFERRED TAX (Contd.)

9.2 Company

	Statement of Financial Position		Statement of Profit or Loss	
	2016	2015	2016	2015
	Rs.	Rs.	Rs.	Rs.
Deferred Tax Assets Arising on:				
Tax Loss Carried Forward	8,906,643	15,490,202	6,583,559	8,123,124
Deferred Tax Expense/(Income)			6,583,559	8,123,124
Net Deferred Tax Asset/(Liability)	8,906,643	15,490,202		

10. INVENTORIES

	Group		Company	
	2016	2015	2016	2015
	Rs.	Rs.	Rs.	Rs.
10.1 Non Current Inventories				
Work in Progress	3,193,406,720	2,362,174,072	-	-
	3,193,406,720	2,362,174,072	-	-
10.2 Current Inventories				
Work in Progress	-	-	-	-
Completed Apartments for Sale	78,059,167	254,835,853	-	-
Consumables and Spares	15,898,784	16,763,615	13,241,224	15,615,804
	93,957,951	271,599,468	13,241,224	15,615,804
10.3 Total Inventories	3,287,364,671	2,633,773,540	13,241,224	15,615,804

10.4 The borrowing cost of Rs 9,937,937/- (Nil-2015) was capitalised to development cost (work in progress).

11. TRADE AND OTHER RECEIVABLES

	Group		Company	
	2016	2015	2016	2015
	Rs.	Rs.	Rs.	Rs.
Rent and Service Charge Receivables	111,073,067	98,122,908	111,073,067	98,122,908
Trade Receivables - Apartment Sales	75,316,563	99,364,096	-	-
	186,389,629	197,487,004	111,073,066	98,122,908
Other Receivables	203,778,776	118,136,651	45,470,160	30,329,617
Accrued Rental Income	185,665,005	275,221,690	184,618,042	275,221,690
	575,833,410	590,845,345	341,161,268	403,674,215
VAT Receivables	252,757,338	237,367,924	-	-
Advances and Prepayments	646,739,895	63,967,722	54,097,885	19,725,857
	1,475,330,643	892,180,991	395,259,153	423,400,072

11.1 As at 31 December, the age analysis of trade receivables, is as follows:

Group	Total	Past Due but not Impaired					
		Before 30 days	31-60 days	61-90 days	91-120 days	> 150 days	
2016	186,389,629	99,645,841	10,305,764	38,465,345	15,456,366	5,980,988	16,535,325
2015	197,487,004	73,727,065	11,069,255	18,287,596	13,602,313	158,726	80,642,049
Company	Total	Before 30 days	31-60 days	61-90 days	91-120 days	121-150 days	> 150 days
2016	111,073,066	39,769,636	9,454,237	57,897,804	(2,780,701)	6,148,006	584,084
2015	98,122,908	55,562,323	8,976,513	18,287,596	13,602,313	158,726	1,535,437

11.2 Rent and Service Charge Receivable are not interest bearing and usually due within 30 days. The Group holds no collateral in respect of these receivables. However the Group is in a position to recover long outstanding dues from rental deposits and customer deposits obtained from customers and tenants.

11.3 There were no charge of reversal in respect of allowance for impairment for 2016 and 2015.

12. AMOUNTS DUE FROM RELATED PARTIES

Relationship	Group		Company	
	2016	2015	2016	2015
	Rs.	Rs.	Rs.	Rs.
Realty Management Services (Pvt) Ltd.	-	-	4,340,457	3,914,592
Mireka Homes (Pvt) Ltd.	-	-	7,069,349	4,774,436
Havelock City (Pvt) Ltd.	-	-	-	158,224
Shing Kwan Investment Lanka (Pvt) Ltd.	-	996,488	-	996,488
Less : Allowance for Impairment	-	996,488	11,409,806	9,843,740
	-	996,488	11,409,806	9,843,740

13. STATED CAPITAL

	2016	2015
	Rs.	Rs.
Stated Capital		
Balance as at 1 January	11,162,751,513	10,186,085,405
Issue of shares during the Year	-	976,666,108
Balance as at 31 December	11,162,751,513	11,162,751,513

Notes to the Financial Statements

Year ended 31 December 2016

13. STATED CAPITAL (Contd.)

	2016 Number	2015 Number
13.2 Number of Ordinary Shares		
Balance as at 1 January	887,878,273	843,484,359
Issue of shares during the Year	-	44,393,914
Balance as at 31 December	887,878,273	887,878,273

14. RESERVES

	Group		Company	
	2016 Rs.	2015 Rs.	2016 Rs.	2015 Rs.
14.1 Revaluation Reserve				
Balance as at 1 January	291,182,354	264,523,391	284,081,947	264,523,391
Acquisition of Subsidiary (Note 8.2)	129,271,904			
Surplus during the Year	50,708,051	33,572,583	36,185,002	19,558,556
Deferred Tax Effect	(2,178,457)	(2,180,016)	-	-
	468,983,852	295,915,958	320,266,949	284,081,947
Revaluation Surplus Attributable to Non Controlling Interest	(4,937,837)	(4,733,604)	-	-
Balance as at 31 December	464,046,015	291,182,354	320,266,949	284,081,947

14.2 Revaluation Reserve represents the surplus related to the regular revaluation as explained in Note 6.3.

15. OTHER FINANCIAL ASSETS AND FINANCIAL LIABILITIES

15.1 Investments in Money Market Funds and Fixed deposits

	As at 01.01.2016 Rs.	Additions/ (Withdrawals) Rs.	Fair Value (Gain)/ Loss Rs.	As at 31.12.2016 Rs.
15.1.1 Group				
Namal High Yield Fund	689,942,439	-	69,532,328	759,474,767
Ceybank Saving Plus	815,123,153	(755,229,447)	25,277,577	85,171,283
Eagle Money Plus Fund	795,699,723	(800,000,000)	52,620,552	48,320,275
Guardian Acuity Asset Management Ltd.	560,945,928	(75,000,000)	58,171,024	544,116,952
Investment in Fixed Deposits	-	35,544,495	-	35,544,495
	2,861,711,243	(1,594,684,952)	205,601,481	1,472,627,772

	As at 01.01.2016 Rs.	Additions/ (Withdrawals) Rs.	Fair Value (Gain)/ Loss Rs.	As at 31.12.2016 Rs.
15.1.2 Company				
Namal High Yield Fund	689,942,439	-	69,532,328	759,474,767
Ceybank Saving Plus	815,123,153	(755,229,447)	25,277,577	85,171,283
Eagle Money Plus Fund	795,699,723	(800,000,000)	52,620,552	48,320,275
Guardian Acuity Asset Management Ltd.	560,945,928	(75,000,000)	58,171,024	544,116,952
	2,861,711,243	(1,630,229,447)	205,601,481	1,437,083,277

15.1.3 Fair values of the Investments in Money Market Funds are ascertained annually using the unit prices of each Trust Funds. These investments are carried in the statement of financial position at fair value with changes in fair value recognised in finance income or finance costs in the statement of profit or loss as disclosed in note 22.2.

	2016		2016		2015		2015	
	Amounts Repayable within 1 Year Rs.	Amounts Repayable after 1 Year Rs.	2016 Total Rs.	Amounts Repayable within 1 Year Rs.	Amounts Repayable after 1 Year Rs.	2015 Total Rs.	Amounts Repayable within 1 Year Rs.	Amounts Repayable after 1 Year Rs.
15.2 Interest Bearing Loans and Borrowings								
15.2.1 Group								
Loan from Bank of Ceylon (BOC) (15.2.3)	284,715,000	-	284,715,000	-	-	-	-	-
SR & CC & T Fund Loan - BOC (15.2.4)	45,797,000	-	45,797,000	50,004,000	45,797,000	50,004,000	45,797,000	95,801,000
Bank Overdrafts (21)	1,949,151,015	-	1,949,151,015	-	-	-	-	-
Loan from Commercial Bank	24,710,153	-	24,710,153	-	-	-	-	-
	2,304,373,168	-	2,304,373,168	50,004,000	45,797,000	50,004,000	45,797,000	95,801,000
15.2.2 Company								
SR & CC & T Fund Loan (15.2.4)	45,797,000	-	45,797,000	50,004,000	45,797,000	50,004,000	45,797,000	95,801,000
Bank Overdrafts *(21)	1,948,050,000	-	1,948,050,000	-	-	-	-	-
Total Loans and Overdraft	1,993,847,000	-	1,993,847,000	50,004,000	45,797,000	50,004,000	45,797,000	95,801,000

* The Company obtained USD 13 Mn as Permanent Overdraft from Bank of Ceylon to partly finance the acquisition of additional interest in Mireka Capital Land (Pvt) Ltd. Terms of banking facility were:
- repayable over 4 years with a reduction of USD 3.25 Mn per annum
- Interest 3% p.a. + 3 months USD LIBOR
- collateral over previously held shareholding (40%) by Bank of Ceylon on Mireka Capital Land (Pvt) Ltd.

Notes to the Financial Statements

Year ended 31 December 2016

15. OTHER FINANCIAL ASSETS AND FINANCIAL LIABILITIES (Contd.)

	As At 01.01.2016 Rs.	Obtained during the Year Rs.	Repayments Rs.	Exchange Difference Rs.	As At 31.12.2016 Rs.
15.2.3 Loan - Bank of Ceylon					
Shareholder Loan - BOC	-	719,732,500	(438,985,000)	3,967,500	284,715,000
	-	719,732,500	(438,985,000)	3,967,500	284,715,000

As per the loan agreement a loan facility of US\$ 40MN has been approved to Mireka Homes (Pvt) Ltd(MHL) in 2012. Interest has been paid monthly at a fixed rate of 5% per annum during the year. The loan proceeds has been utilized for Phase III & IV of Havelock City Apartment Project.

	As at 01.01.2016 Rs.	Loans Obtained during the Year Rs.	Repayments Rs.	As At 31.12.2016 Rs.
15.2.4 Unsecured Bank Loans				
SR & CC & T Fund Loan - BOC (15.2.5)	95,801,000	-	(50,004,000)	45,797,000
	95,801,000	-	(50,004,000)	45,797,000

15.2.5 The Company signed an unsecured Term Loan Agreement on 30 March 1998 with Bank of Ceylon (BOC) to borrow Rs.500 million at a rate of interest of 2% p.a. repayable over a period of ten years following a grace period of five years. Accordingly, the repayment was to begin in April 2003. Following negotiations, the repayment of capital was extended by a further 5 years. The first capital repayment therefore commenced in December 2007.

16. POST EMPLOYMENT BENEFIT LIABILITY

	Group		Company	
	2016 Rs.	2015 Rs.	2016 Rs.	2015 Rs.
Balance as at 1 January	26,511,177	21,274,742	11,650,115	8,352,270
Transfer	(4,874,230)	-	248,000	-
	21,636,947	21,274,742	11,898,115	8,352,270
Charge for the Year (16.1)	5,949,374	6,477,655	2,971,391	2,784,621
Actuarial (Gain)/ Loss	2,641,492	(1,090,965)	586,419	513,224
Payments Made during the Year	(3,671,567)	(150,255)	(924,935)	-
Balance as at 31 December	26,556,246	26,511,177	14,530,990	11,650,115

16.1 Post Employee Benefit Expense for Year Ended 31 December

	Group		Company	
	2016 Rs.	2015 Rs.	2016 Rs.	2015 Rs.
Current Service Cost	3,870,064	4,775,675	1,827,982	2,116,439
Interest Cost	2,079,311	1,701,980	1,143,409	668,182
Post Employment Benefit Expense	5,949,374	6,477,655	2,971,391	2,784,621

16.2 Messrs. Piyal S Goonetilleke and Associates : Actuaries, carried out an actuarial valuation of the Group as at 31 December 2016. Appropriate and compatible assumptions were used in determining the cost of post employment benefits. The principal assumptions used are as follows:

	2016	2015
a) Demographic Assumptions		
Retirement Age :	55 Years	55 Years
b)		
Assumed rate of employee turnover is 10% from age 20 to age 30. Such is estimated to decrease between 5% to 3% in respect of ages 35 to 40, from which point onwards up to retirement it is estimated at 1% p.a.		
c) Financial Assumptions		
Discount Rate	12.30%	9.61%
Salary Increment Rate	8%	8%
Expected Average Future Working Life of Employees	5.7 years	5.7 years

16.3 Sensitivity of Assumptions Employed in Actuarial Valuation

The following table demonstrates the sensitivity to a reasonable possible change in the key assumptions used, with all other variables held constant in the post employment benefit liability measurement, in respect of the year 2016.

The sensitivity of the Statement of Profit or Loss and Statement of Financial Position is the effect of the assumed changes in discount rate and salary increment rate on the profit or loss and post employment benefit obligation for the year.

	Increase/(Decrease)		Group 2016		Company 2016	
	In Discount Rate	In Salary Increment Rate	Effect on Income Statement (reduction)/ increase in results for the Year	Preforma Post Employment Benefit Liability	Effect on Income Statement (reduction)/ increase in results for the Year	Preforma Post Employment Benefit Liability
-1%	-	-	(1,363,455)	27,919,701	(746,052)	15,277,042
1%	-	-	1,250,830	25,305,416	684,426	13,846,564
-	-1%	-1%	2,097,408	24,458,838	1,147,655	13,383,335
-	-	1%	(1,172,292)	27,728,538	(641,452)	15,172,442

Notes to the Financial Statements

Year ended 31 December 2016

17. TRADE AND OTHER PAYABLES

	Group		Company	
	2016 Rs.	2015 Rs.	2016 Rs.	2015 Rs.
Trade Payables - Related Parties	-	-	-	-
- Payable to Contractor	295,269,790	153,353,884	-	-
- Others	148,308,872	143,885,716	-	-
	443,578,662	297,239,600	-	-
Other Payables	-	11,312,402	-	-
Rental Income Received in Advance	104,843,565	135,843,604	104,843,565	135,843,604
Sundry Creditors including Accrued Expenses	336,328,889	337,770,564	234,343,063	193,487,688
	884,751,116	782,166,170	339,186,628	329,331,292

18. RENTAL AND CUSTOMER DEPOSITS

	Group		Company	
	2016 Rs.	2015 Rs.	2016 Rs.	2015 Rs.
Rental Deposits	856,450,089	875,469,328	841,728,195	875,469,328
Customer Deposits	1,214,792,590	322,786,412	-	-
	2,071,242,679	1,198,255,740	841,728,195	875,469,328
Classified Under:				
Current Liabilities	856,450,089	875,469,328	841,728,195	875,469,328
Non Current Liabilities	1,214,792,590	322,786,412	-	-
	2,071,242,679	1,198,255,740	841,728,195	875,469,328

19. AMOUNTS DUE TO RELATED PARTIES

	Relationship	Group		Company	
		2016 Rs.	2015 Rs.	2016 Rs.	2015 Rs.
Mireka Capital Land (Pvt) Ltd.	Subsidiary	-	-	2,796,885	3,265,480
Management Corporation Condominium Plan 1824	Other Related Party	34,991,690	21,171,041	34,991,690	21,171,041
Shing Kwan Investment Lanka (Pvt) Ltd.	Subsidiary	4,610	-	4,610	-
Shing Kwan Investment (Singapore) Pte Ltd	Other Related Party	758,609,100	-	-	-
		793,610,010	21,171,041	37,793,185	24,436,521

20. DIVIDENDS PAID AND PAYABLE

	2016	2015
	Rs.	Rs.
20.1 Declared and Paid during the Year		
Equity Dividends on Ordinary Shares		
- Final dividend for 2016 Rs.1.50 : (2015- Rs. Rs. 1.50)	1,331,817,410	1,265,226,539
	1,331,817,410	1,265,226,539
20.2 Dividends Payable as at the end of the Year		
Dividends on Ordinary Shares Unclaimed	13,297,096	6,713,174
	13,297,096	6,713,174

21. CASH AND SHORT TERM DEPOSITS

	Group		Company	
	2016	2015	2016	2015
	Rs.	Rs.	Rs.	Rs.
Cash and Bank Balances	158,952,631	163,246,359	130,737,832	132,007,681
Call Deposits and Fixed Deposits	1,184,936,651	1,502,852,758	331,978,830	1,268,277,041
	1,343,889,282	1,666,099,117	462,716,662	1,400,284,722
Bank Overdraft (15)	(1,949,151,015)	-	(1,948,050,000)	-
Total Cash and Cash Equivalents for the Purpose of Cash Flow Statement	(605,261,733)	1,666,099,117	(1,485,333,338)	1,400,284,722

22. FINANCE COST AND INCOME

	Group		Company	
	2016	2015	2016	2015
	Rs.	Rs.	Rs.	Rs.
22.1 Finance Cost				
Interest Expense on Interest Bearing Loans and Borrowings	11,092,096	9,579,170	1,649,493	2,379,929
Fair Value Adjustment on Rental Deposits	43,484,797	2,760,101	42,116,107	2,760,101
	54,576,893	12,339,271	43,765,600	5,140,030
22.2 Finance Income				
Income from Investments				
- Interest on Fixed Deposits	74,623,359	76,774,967	55,540,661	74,176,040
- Interest on Government Securities (REPO)	7,447,928	5,675,954	-	-
- Income from Investment in Fair Value through Profit & Loss	205,601,481	97,367,140	205,601,481	97,367,140
Amortization of Deferred Lease Interest Income on Rental Deposits	44,113,734	1,754,897	42,763,431	1,754,897
	331,786,502	181,572,958	303,905,573	173,298,077
22.3 Other Income				
Dividend Income	52,157,725	59,609,044	110,411,725	115,959,244
Club House Income	33,106,915	24,680,137	-	-
	85,264,640	84,289,181	110,411,725	115,959,244

Notes to the Financial Statements

Year ended 31 December 2016

23. PROFIT BEFORE TAX Stated after Charging /(Crediting)

	Group		Company	
	2016 Rs.	2015 Rs.	2016 Rs.	2015 Rs.
Directors Fee	5,825,000	6,050,000	5,050,000	5,125,000
Auditors Remuneration	3,255,024	3,450,546	1,882,666	1,631,750
Depreciation Charge for the Year	33,546,040	30,518,480	12,686,369	10,637,753
Exchange (Gain)/Loss	11,032,104	9,664,790	3,988,262	5,887,498
(Profit)/Loss on Disposal/Discontinuation of Property, Plant and Equipment	(3,871,489)	(5,952,721)	(3,871,489)	(5,952,721)
Employee Benefit Expenses Including the following;				
- Defined Benefit Plan Cost - Gratuity	5,949,374	6,477,655	2,971,391	2,784,621
- Defined Contribution Plan Cost - EPF & ETF	22,189,028	11,545,385	9,878,816	8,922,461
Amortization / write off of Intangible Assets	10,265,116	1,470,252	1,470,252	1,470,252

24. TAX EXPENSES

The major components of income tax expense for the years ended 31 December 2015 and 31 December 2016 are as follows :

24.1 Statement of Profit or Loss

	Group		Company	
	2016 Rs.	2015 Rs.	2016 Rs.	2015 Rs.
Current Tax Expense on Other Income	23,545,545	24,032,558	12,226,610	14,644,734
Under/(Over) Provision of Current Taxes in respect of Prior Year	-	557,731	-	441,168
Deferred tax:				
Deferred Taxation Charge/(Credit)	20,190,283	17,467,354	6,583,559	8,123,124
Income Tax Expense /(Credit) Reported in the Statement of Profit or Loss	43,735,828	42,057,643	18,810,169	23,209,026

24.2 Reconciliation between tax expense and the product of accounting profit multiplied by the statutory tax rate is as follows:

	Group		Company	
	2016 Rs.	2015 Rs.	2016 Rs.	2015 Rs.
Accounting Profit Before Tax	2,973,853,329	3,072,911,070	2,943,793,571	2,890,021,275
Income Exempted from Tax	(2,945,327,538)	(2,977,652,271)	(2,876,614,397)	(2,809,555,894)
Less : Other Income	(64,617,150)	(76,799,357)	(51,011,879)	(69,401,889)
Aggregate Disallowed Items	33,866,760	26,804,706	-	-
Aggregate Allowed Item	(112,352,350)	(78,952,877)	-	-
Net Profit /(Loss) from Trade	(114,576,949)	33,688,728	16,167,295	11,063,492
Other Income	64,617,150	76,799,357	51,011,879	69,401,889
Total Statutory Income	106,743,069	114,166,671	67,179,174	52,302,622
Less Tax Losses Claimed	(23,969,475)	(28,336,106)	(23,512,711)	(28,162,759)
Assessable Liabile Income	82,773,594	85,830,565	43,666,463	52,302,622
Income Tax at the Statutory Rate 15% - 28%	23,545,545	24,032,558	12,226,610	14,644,734
Current Tax Expense on Other Income	23,545,545	24,032,558	12,226,610	14,644,734

24.3 The above current tax expense relates to the interest income and other miscellaneous income that are not covered by the tax exemption enjoyed by Overseas Realty (Ceylon) PLC and its subsidiaries as detailed in note 2.3.3.

24.4 The carried forward unutilized tax losses of the Company and Group respectively as at 31 December 2016 amounted to Rs.31,809,438/- and Rs.102,821,531/- (2015-Rs.55,322,149/- and 126,583,547/-) respectively

25. EARNINGS PER SHARE

25.1 Earnings Per Share is calculated by dividing the net profit for the year attributable to ordinary shareholders by the number of ordinary shares outstanding during the year. The weighted average number of ordinary shares outstanding during the year and the previous year are adjusted for events that have changed the number of ordinary shares outstanding, without a corresponding change in the resources such as a bonus issue.

25.2 The following reflects the income and share data used in the earnings per share computation.

	Group	
	2016 Rs.	2015 Rs.
Amounts Used as the Numerator		
Net Profit Attributable to Shareholders for Earnings Per Share	2,911,371,018	2,990,698,564
Number of Ordinary Shares Used as the Denominator		
Weighted Average Number of Ordinary Shares in Issue Applicable to Earnings Per Share (25.3)	887,878,273	869,887,034

Notes to the Financial Statements

Year ended 31 December 2016

25. EARNINGS PER SHARE (Contd.)

25.3 Weighted Average Number of Ordinary Shares in Issue Applicable to Earnings Per Share

	Group	
	2016	2015
Ordinary Shares at the beginning of the year	869,887,034	843,484,359
Bonus Element on Right Issue	-	5,537,096
Effect of Right Issue	17,991,239	20,865,579
Weighted Average Number of Ordinary Shares in Issue	887,878,273	869,887,034

26. RELATED PARTY DISCLOSURES

26.1 Transactions with Related Entities

	Group		Company	
	2016 Rs.	2015 Rs.	2016 Rs.	2015 Rs.
26.1.1 Subsidiaries				
Amounts Receivable as at 1 January	-	-	5,581,772	3,233,523
Amounts Payable as at 1 January	-	-	-	(4,657,632)
Rendering of Services	-	-	13,117,239	7,420,517
Reimbursements / (Settlements)	-	-	(10,086,090)	(414,636)
Amounts Receivable as at 31 December	-	-	8,612,921	5,581,772
Amounts Payable as at 31 December	-	-	-	-
26.1.2 Fellow Subsidiaries				
Amounts Receivable as at 1 January	996,488	82,372	996,488	82,372
Amounts Payable as at 1 January	-	-	-	-
Receipt of Loan	(758,692,603)	-	-	-
Receipt of Services	-	1,200,000	-	1,200,000
(Reimbursements) / Settlements	(917,595)	(285,884)	(1,001,098)	(285,884)
Amounts Receivable as at 31 December	-	996,488	-	996,488
Amounts Payable as at 31 December	(758,613,710)	-	(4,610)	-

The above transactions are included in Current Liabilities as Amounts Due to Related Parties and in Current Assets as Amounts due from Related Parties.

Terms and Conditions

Transactions with related parties are carried out in the ordinary course of the business. Outstanding current account balances at year end are unsecured, interest free and settlement occurs in cash. The intention of the Group is to settle such related party dues within a short term (less than one year).

26.1.3 Other Related Parties

a) Management Corporation Condominium Plan 1824

	Group		Company	
	2016 Rs.	2015 Rs.	2016 Rs.	2015 Rs.
Amounts Receivable as at 1 January	-	8,583,920	-	8,583,920
Amounts Payable as at 1 January	(21,171,041)	-	(21,171,041)	-
Facility Management Fee	22,440,000	22,440,000	22,440,000	22,440,000
Membership Fee Collected on behalf	(384,453,600)	(384,453,600)	(384,453,600)	(384,453,600)
Due on account of Supply of Electricity	247,732,230	246,474,726	247,732,230	246,474,726
Other Expense Borne on behalf	100,460,721	85,783,913	57,914,312	85,783,913
Amounts Receivable as at 31 December	-	-	-	-
Amounts Payable as at 31 December	(34,991,690)	(21,171,041)	(77,538,099)	(21,171,041)

Management Corporation Condominium Plan No.1824 ("Corporation") is a body corporate constituted on 4 July 2001 in terms of the provisions of Apartment Ownership (Amendment) Act No.45 of 1982, upon the registration of Condominium Plan No. 1824, which converted the World Trade Center into a Condominium Property. The Chairman of the Council of the Corporation which consists of all the owners (currently 5 owners) were appointed by Overseas Realty Ceylon PLC.

26.2 Transactions with Key Management Personnel of the Company or its Subsidiaries

- a) The Key Management Personnel are the members of the Board of Directors, of the company and of its parent, and the Chief Executive Officer and members of the Management Committee of the Group.

Payments made to Key Management Personnel during the year were as follows:

	2016 Rs.	2015 Rs.
Fees for Directors	5,825,000	6,050,000
Emoluments	74,488,937	66,198,102
Short Term Employment Benefits	9,066,000	8,640,000
Post Employment Benefits	10,847,220	8,221,471
	100,227,157	89,109,573

27. COMMITMENTS

As at the reporting date the following amounts have been agreed and consequently committed to future capital and operating expenditure in respect of project under development.

	Group		Company	
	2016 Rs.	2015 Rs.	2016 Rs.	2015 Rs.
Contracted but not Provided for				
Enterprise Resources Planning	1,162,157	1,162,157	1,162,157	1,162,157
Havelock City Project	5,310,000,000	93,000,000	-	-
	5,311,162,157	94,162,157	1,162,157	1,162,157

Letters of Credit opened with Banks Favouring Suppliers by the Group and the Company amounted to Rs. 23,317,520/- (2015 - 72,624,800/-) and Rs. 23,317,520/- (2015- 72,624,800/-) respectively.

Notes to the Financial Statements

Year ended 31 December 2016

28. CONTINGENCIES

Legal Claim:

The following entities in the Group are involved in legal actions described below. Although there can be no assurance, the Directors believe, based on the information currently available, that the ultimate resolution of such legal procedures would be favorable to the Company and therefore would not have an adverse effect on the results of operations or financial position. Accordingly, no provision for any liability has been made in these Financial Statements.

The Company's subsidiary Mireka Capital Land (Pvt) Ltd was assessed for Value Added Tax (VAT) for periods between January 2006 and January 2009 amounting to Rs 190 Mn plus penalties. The Company appealed against same and filed a Writ Application in the Court of Appeal to prevent recovery action being taken by Authorities. The Company appealed at the Tax Appeal Commission (TAC) on the same matter and the TAC Determination has been issued dismissing the said appeal of the Company. The Company appealed against the TAC Determination in the court of Appeal. Although there can be no assurance, the Directors believe, based on the expert advise received and the information currently available, that the ultimate resolution of the said legal proceedings would be favorable to the Company and therefore would not have an adverse effect on the results of operations or financial position. Accordingly, no provision for any liability has been made in these Financial Statements.

The Company's subsidiary Mireka Homes (Pvt) Ltd (MHL) has been assessed for ESC amounting to Rs 2.9 Mn plus penalties and the Company has appealed against same. Further the Department of Inland Revenue has raised assessments disallowing Input VAT of Rs 324 Mn and the Company has appealed against same. Although there can be no assurance, the Directors believe, based on the information currently available, that the ultimate resolution of appeal/ legal proceedings would be favorable to the Company and therefore would not have an adverse effect on the results of operations or financial position. Accordingly, no provision for any liability has been made in these Financial Statements.

29. ASSETS PLEDGED

Except as disclosed in Note 15.2.2, the Company has not pledged any asset for any business transaction.

30. EVENTS OCCURING AFTER THE REPORTING DATE

The Board of Directors of the Company on 23rd September 2016, resolved to raise a sum of Rs 7,280,601,834/- by way of a Rights Issue of Three Hundred and Fifty Five Million One Hundred and Fifty One Thousand Three Hundred and Nine (355,151,309) new Ordinary Shares at a price of Rupees Twenty and Cents Fifty (Rs. 20.50) per share in the proportion of Two (02) Ordinary Shares for every Five (05) existing Ordinary Shares in the Company, towards its investment in the proposed Mixed Development Project of Havelock City (Private) Limited (Project], which was approved by the Company Shareholders at the Extra Ordinary General Meeting held on 23rd December 2016 and fully subscribed on 17th January 2017.

The Board of Directors of the Company has declared a final dividend of Rs. 1.25 per share for the financial year ended 31 December 2016. As required by section 56 (2) of the Companies Act No 07 of 2007, the Board of Directors has confirmed that the Company satisfies the solvency test in accordance with section 57 of the Companies Act No 07 of 2007. Dividend is to be approved by shareholders at the Annual General Meeting of the Company.

31. FINANCIAL RISK MANAGEMENT OBJECTIVES AND POLICIES

The Group is exposed to interest rate risk, foreign currency risk, credit risk and liquidity risk. The Company's Board of Directors oversees the management of these risks. The Board of Directors is supported by an Audit Committee that advises on financial risks and the appropriate financial risk governance framework for the Group. The Audit Committee provides guidance to the Board of Directors that the Group's financial risk-taking activities are governed by appropriate policies and procedures and that financial risks are identified, measured and managed in accordance with policies.

The Board of Directors reviews and agrees policies for managing each of these risks which are summarised below.

31.1 Market Risk

Market risk is the risk that changes in market prices, such as foreign exchange rates, interest rates and unit prices will affect the Group's income or the value of its holdings of financial instruments.

An analysis of the carrying amount of financial instruments based on the currency they are denominated are as follows:

	Denominated in LKR	Denominated in USD
Group		
Cash at bank and in hand	313,305,603	(12,800,404)
Short term deposits	288,785,146	6,508,593
Short Term Investments	1,437,083,277	1,900,000
Interest Bearing Loans & Borrowings	45,797,000	13,000,000
Company		
Cash at bank and in hand	292,511,860	(12,842,580)
Short term deposits	170,204,802	1,370,642
Other Financial Assets (Unit Trust Investments)	1,437,083,277	-
Interest Bearing Loans & Borrowings	45,797,000	13,000,000

a) Interest Rate Risk

Interest rate risk is the risk that the fair value or future cash flows of a financial instrument will fluctuate because of changes in market interest rates. The Group's exposure to the risk of changes in market interest rates relates primarily to the Group's long-term debt obligations. The Group manages its interest rate risk by monitoring and managing of cash flow, by keeping borrowings to a minimum and negotiating favorable rates on borrowings and deposits and by borrowing at fixed rates.

Notes to the Financial Statements

Year ended 31 December 2016

31 FINANCIAL RISK MANAGEMENT OBJECTIVES AND POLICIES (Contd.)

b) Foreign Currency Risk

The Group's exposure to the risk of changes in foreign exchange rates relates primarily to the Group's USD denominated loans for the Havelock City Project.

The Group manages its foreign currency risk by entering into construction contracts in LKR and building in the foreign exchange loss into the cost of development.

The following table demonstrates the sensitivity to a reasonably possible change in the US dollar exchange rate, with all other variables held constant, on the Group's profit before tax, due to possible changes in the USD exchange rate, on the Group's USD denominated interest bearing loan.

	Average Loan Value	Year End Exchange Rate	Change In USD Rate	Effect on Profit Before Tax
2016	USD 2.40 Mn	149.85	+/-7.5%	27,133,554
2015	USD 0.57 Mn	143.75	+/-7.5%	6,165,845

31.2 Credit Risk

Credit risk is the risk that a counterparty will not meet its obligations under a financial instrument or customer contract, leading to a financial loss. The Group is exposed to credit risk from its operating activities (primarily for trade receivables) and from its financing activities, including deposits with banks and financial institutions.

Trade receivables

Customer credit risk is managed by each business unit subject to the Group's established policy, procedures and control relating to customer credit risk management.

The following practice are implemented within the Group in order to manage credit risk related to receivables:

- Adequate customer deposits are collected from lessees of leased property.
- Outstanding customer receivables are regularly monitored with regular trade debtor review meetings.
- Contractual obligation to release assets only upon full payment of receivable, for related contracts and assets.

Credit quality information is provided in Note 11.

Notes to the Financial Statements

Year ended 31 December 2016

32. CAPITAL MANAGEMENT

The stated capital of the Company, and Group reserves are given in Note 13 and 14.

33. FAIR VALUES

Set out below is a comparison of the carrying amounts and fair values of the Group's financial instruments by classes, that are not carried at fair value in the financial statements.

This table does not include the fair values of non-financial assets and non-financial liabilities.

Group	Notes	Carrying Amount		Fair Value	
		2016 Rs.	2015 Rs.	2016 Rs.	2015 Rs.
Financial Assets					
Trade and Other Receivables	B	575,833,410	590,845,345	575,833,410	590,845,345
Amounts Due from Related Parties	B	-	996,488	-	996,488
Short Term Investments	B	1,472,627,772	2,861,711,243	1,472,627,772	2,861,711,243
Cash and Short Term Deposits	B	1,343,889,282	1,666,099,117	1,343,889,282	1,666,099,117
Total		3,392,350,465	5,119,652,193	3,392,350,465	5,119,652,193
Financial Liabilities					
Interest Bearing Loans and Borrowings (Non-Current)	A	-	45,797,000	-	45,797,000
Trade and Other Payables	B	884,751,116	782,166,170	884,751,116	782,166,170
Amounts Due to Related Parties	B	793,610,010	21,171,041	793,610,010	21,171,041
Interest Bearing Loans and Borrowings (Current)	B	2,304,373,168	50,004,000	2,304,373,168	50,004,000
Rental Deposits	C	856,450,089	875,469,328	856,450,089	875,469,328
Total		4,839,184,382	1,774,607,539	4,839,184,382	1,774,607,539
Company	Notes	Carrying Amount		Fair Value	
		2016 Rs.	2015 Rs.	2016 Rs.	2015 Rs.
Financial Assets					
Trade and Other Receivables	B	341,161,268	403,674,215	341,161,268	403,674,215
Amounts Due from Related Parties	B	11,409,806	9,843,740	11,409,806	9,843,740
Short Term Investments	B	1,437,083,277	2,861,711,243	1,437,083,277	2,861,711,243
Cash and Short Term Deposits	B	462,716,662	1,400,284,722	462,716,662	1,400,284,722
Total		2,252,371,013	4,675,513,920	2,252,371,013	4,675,513,920
Financial Liabilities					
Interest Bearing Loans and Borrowings (Non-Current)	A	-	45,797,000	-	45,797,000
Trade and Other Payables	B	339,186,628	329,331,292	339,186,628	329,331,292
Amounts Due to Related Parties	B	37,793,185	24,436,521	37,793,185	24,436,521
Interest Bearing Loans and Borrowings (Current)	B	1,993,847,000	50,004,000	1,993,847,000	50,004,000
Rental Deposits	C	841,728,195	875,469,328	841,728,195	875,469,328
Total		3,212,555,008	1,325,038,141	3,212,555,008	1,325,038,141

The fair values of the financial assets and liabilities are included at the amount at which the instrument could be exchanged in a current transaction between willing parties, other than in a forced or liquidation sale. The following methods and assumptions were used to estimate the fair values:

- A** Long-term fixed-rate receivables/borrowings are evaluated based on parameters such as interest rates, risk characteristics of the financed project etc. As at 31 December 2016, the carrying amounts of such borrowings are not materially different from their calculated fair values.
- B** Cash and short-term deposits, trade receivables, trade payables and other current liabilities approximate their carrying amounts largely due to the short-term maturities of these instruments.
- C** The fair value of rental deposits (other than liabilities with maturities within 12 months) carried at amortised cost are estimated by comparing market interest rates when they were first recognised with current market rates for similar financial instruments. Rental deposits fall into the category Level 2 of Fair value hierarchy.

a) Fair value hierarchy

The Group uses the following hierarchy for determining and disclosing the fair value of financial assets by valuation technique:

Level 1: quoted (unadjusted) prices in active markets for identical assets or liabilities

Level 2: other techniques for which all inputs which have a significant effect on the recorded fair value are observable, either directly or indirectly.

Level 3: techniques which use inputs that have a significant effect on the recorded fair value that are not based on observable market data

As at 31 December 2016, the Group held the following financial instruments carried at fair value on the statement of financial position:

b) Financial Assets measured at fair value

	2016 Rs.	Level 1 Rs.	Level 2 Rs.	Level 3 Rs.
Short Term Investments (Note 15.1)	1,437,083,277	-	1,437,083,277	-

During the reporting period ending 31 December 2016, there were no transfers between Level 1 and Level 2 fair value measurements.

Notes to the Financial Statements

Year ended 31 December 2016

35. ANALYSIS OF FINANCIAL ASSETS AND LIABILITIES BY MEASUREMENT BASIS

Financial assets and financial liabilities are measured on an ongoing basis at either fair value or amortised cost. The summary of significant accounting policies describes how the classes of financial instruments are measured, and how income and expenses, including fair value gains and losses are recognised. The following table analyses the carrying amount of financial assets and liabilities by category as defined in LKAS 39 - Financial Instruments : Recognition and measurement and by Statement of Financial Position heading:

As at 31 December 2016	Financial Assets Held for Trading						Financial Assets and Liabilities at Amortised Cost		Total	
	at Fair Value		Company		Group		Company		Group	
	Group	Company	Rs.	Rs.	Rs.	Rs.	Rs.	Rs.	Rs.	Rs.
Group/ Company										
Financial Assets										
Trade and Other Receivables	-	-	575,833,410	341,161,268	575,833,410	341,161,268	-	-	1,437,083,277	1,437,083,277
Amounts Due from Related Parties	-	-	-	11,409,806	-	11,409,806	-	-	-	11,409,806
Short Term Investments	1,437,083,277	1,437,083,277	35,544,495	-	1,472,627,772	-	-	1,472,627,772	1,437,083,277	1,437,083,277
Cash and Short Term Deposits	-	-	1,343,889,282	462,716,662	1,343,889,282	462,716,662	-	-	1,343,889,282	462,716,662
Total Financial Assets	1,437,083,277	1,437,083,277	1,955,267,187	815,287,736	3,392,350,465	815,287,736	-	-	2,252,371,013	2,252,371,013
Financial Liabilities										
Trade and Other Payables	-	-	884,751,116	339,186,628	884,751,116	339,186,628	-	-	884,751,116	339,186,628
Amounts Due to Related Parties	-	-	793,610,010	37,793,185	793,610,010	37,793,185	-	-	793,610,010	37,793,185
Interest Bearing Loans and Borrowings (Current)	-	-	2,304,373,168	1,993,847,000	2,304,373,168	1,993,847,000	-	-	2,304,373,168	1,993,847,000
Rental Deposits	-	-	856,450,089	841,728,195	856,450,089	841,728,195	-	-	856,450,089	841,728,195
Total Financial Liabilities	-	-	4,839,184,382	3,212,555,008	4,839,184,382	3,212,555,008	-	-	4,839,184,382	3,212,555,008

As at 31 December 2015	Financial Assets Held for Trading						Financial Assets and Liabilities at Amortised Cost					
	at Fair Value			Amortised Cost			Total					
	Group	Company	Rs.	Group	Company	Rs.	Group	Company	Rs.	Group	Company	Rs.
Group/ Company												
Financial Assets												
Trade and Other Receivables	-	-	-	590,845,345	403,674,215	590,845,345	403,674,215					
Amounts Due from Related Parties	-	-	-	996,488	9,843,740	996,488	9,843,740					
Short Term Investments	2,861,711,243	2,861,711,243		-	-	2,861,711,243	2,861,711,243					
Cash and Short Term Deposits	-	-	-	1,666,099,117	1,400,284,722	1,666,099,117	1,400,284,722					
Total Financial Assets	2,861,711,243	2,861,711,243		2,257,940,950	1,813,802,677	5,119,652,193	4,675,513,920					
Financial Liabilities												
Interest Bearing Loans and Borrowings (Non-Current)				45,797,000	45,797,000	45,797,000	45,797,000					
Trade and Other Payables	-	-	-	782,166,170	329,331,292	782,166,170	329,331,292					
Amounts Due to Related Parties	-	-	-	21,171,041	24,436,521	21,171,041	24,436,521					
Interest Bearing Loans and Borrowings (Current)	-	-	-	50,004,000	50,004,000	50,004,000	50,004,000					
Rental Deposits (Current)	-	-	-	875,469,328	875,469,328	875,469,328	875,469,328					
Total Financial Liabilities	-	-	-	1,774,607,539	1,325,038,141	1,774,607,539	1,325,038,141					

Group Performance - Ten Year Summary

Rs. Mn	2016	2015	2014	2013	2012	2011	2010	2009	2008	2007
STATEMENT OF PROFIT OR LOSS										
Rental Revenue	1,886	1,962	1,764	1,590	1,339	850	697	666	805	716
Revenue from Other Services	259	205	104	69	54	57	51	41	42	35
Apartment Revenue	285	974	4,329	3,190	554	1,588	950	1,234	598	379
Total Revenue	2,431	3,141	6,198	4,848	1,948	2,495	1,698	1,941	1,445	1,130
Direct Operating Expenses	(615)	(548)	(482)	(424)	(426)	(338)	(329)	(334)	(350)	(271)
Cost of Sales of Apartment	(160)	(653)	(3,308)	(2,635)	(397)	(1,231)	(633)	(1,051)	(403)	(328)
Gross Profit	1,656	1,940	2,408	1,789	1,125	926	736	556	692	531
Fair Value Gain on Investment Property	1,267	1,175	1,016	930	1,563	2,123	473	1,019	1,388	1,834
Other Operating Expenses	(323)	(305)	(266)	(268)	(260)	(270)	(274)	(187)	(202)	(178)
Net Finance Income / (Expense)	277	169	155	175	176	27	(94)	3	43	43
Profit from Operating Activities	2,878	2,979	3,312	2,626	2,604	2,806	841	1,391	1,921	2,230
Other Income	85	84	64	-	-	-	-	-	-	-
Exchange Gain / (Loss)	11	10	10	15	(85)	(40)	84	-	(88)	-
Net Profit Before Tax	2,974	3,073	3,386	2,641	2,519	2,766	925	1,391	1,833	2,230
Income Taxes	(44)	(42)	(50)	(2)	(51)	(25)	(11)	(7)	(16)	(17)
Net Profit After Tax	2,930	3,031	3,336	2,639	2,468	2,741	914	1,384	1,817	2,213
Profit Attributable to Equity Holders of the Parent	2,911	2,991	2,957	2,435	2,469	2,681	844	1,342	1,783	2,197
Non-controlling Interest	19	40	379	204	(1)	60	70	43	33	16
	2,930	3,031	3,336	2,639	2,468	2,741	914	1,384	1,817	2,213
STATEMENT OF FINANCIAL POSITION										
Assets										
Non-Current Assets										
Investment Property	24,652	22,579	21,405	20,389	19,459	17,884	15,751	15,278	14,259	12,870
Property Plant & Equipment	1,782	1,598	1,559	703	644	395	254	246	236	215
Intangible Assets	2	12	14	18	18	26	30	35	15	16
Inventory	3,193	2,362	2,125	1,785	-	-	-	-	-	-
Deferred Tax Assets	149	29	27	41	-	-	-	-	-	-
	29,779	26,581	25,130	22,937	20,122	18,305	16,035	15,560	14,510	13,101
Current Assets										
Inventory	94	272	424	3,565	4,129	3,167	3,981	4,093	4,226	3,108
Trade & Other Receivables	1,475	892	1,379	1,448	1,839	1,563	1,275	1,635	971	579
Amounts due From Related Parties	-	1	9	25	14	25	53	4	22	3
Income Tax Recoverable	17	-	10	2	-	-	1	1	-	-
Short Term Investments	1,473	2,862	2,155	1,236	-	-	-	-	-	-
Cash & Short Term Deposits	1,344	1,666	1,170	1,680	1,811	2,197	1,008	177	244	902
	4,402	5,693	5,146	7,956	7,793	6,952	6,318	5,910	5,462	4,592
TOTAL ASSETS	34,181	32,274	30,276	30,893	27,915	25,257	22,353	21,470	19,972	17,693
Equity & Liabilities										
Stated Capital	11,163	11,163	10,186	10,186	10,186	10,186	10,186	9,713	9,713	9,713
Revaluation Reserve	464	291	265	239	216	165	149	135	112	80
Retained Earnings	16,207	17,151	15,478	13,750	11,559	9,343	6,915	6,283	5,241	3,813
Equity Attributable to Equity Holders	27,833	28,605	25,929	24,175	21,961	19,694	17,250	16,131	15,066	13,606
Minority Interest	-	1,512	1,507	1,147	943	963	903	833	791	758
Total Equity	27,833	30,117	27,436	25,322	22,904	20,657	18,153	16,964	15,857	14,364

Rs. Mn	2016	2015	2014	2013	2012	2011	2010	2009	2008	2007
Non-Current Liabilities										
Interest Bearing Loans & Borrowings	-	46	96	146	196	246	2,194	1,549	567	1,135
Non Interest Bearing Borrowings & Loans	-	-	-	-	-	-	1	2	3	4
Post Employment Benefit Liability	27	27	21	18	27	23	21	20	18	15
Customer Deposit	1,215	323	-	-	-	-	-	-	-	-
Deferred Tax Liability	226	23	-	-	-	-	-	-	-	-
	1,468	418	117	163	223	269	2,216	1,571	588	1,154
Current Liabilities										
Trade & Other Payables	885	782	825	1,594	543	697	871	831	996	2,056
Rental & Customer Deposits	856	875	904	1,888	2,082	976	418	440	925	-
Amounts Due to Related Parties	794	21	-	12	20	9	9	26	13	19
Interest Bearing Loans & Borrowings	2,304	50	986	1,888	2,117	2,636	683	1,596	1,587	50
Non Interest Bearing Borrowings & Loans	-	-	-	-	-	1	1	1	1	1
Income Tax Payable	27	4	2	21	24	10	-	-	4	11
Dividend Payable	13	7	5	3	3	2	2	39	1	38
	4,880	1,739	2,723	5,407	4,788	4,331	1,984	2,935	3,527	2,175
TOTAL EQUITY & LIABILITIES	34,181	32,274	30,276	30,893	27,915	25,257	22,353	21,470	19,972	17,694
Earnings Per Share	3.28	3.44	3.48	2.89	2.93	3.18	1.23	2.25	3.04	3.74
Earnings Per Share (Excluding Fair Value Gains))	1.85	2.09	2.29	1.78	1.07	0.66	0.58	0.57	0.70	0.61
Dividend Per Share	1.50	1.50	1.45	0.30	0.30	0.30	0.26	0.40	0.50	0.30
Net Asset Value Per Share	31.35	32.22	30.74	28.66	26.04	23.35	20.45	28.69	26.79	24.20
Share Value (High)	26.10	24.10	29.30	21.30	15.60	19.40	24.00	15.00	15.00	15.50
Share Value (Low)	19.30	20.50	18.50	13.90	9.50	13.10	14.00	5.75	5.75	9.00
Current Ratio	0.90	3.27	1.89	1.47	1.63	1.61	3.18	2.01	1.55	2.11
Return on equity (%)	10%	11%	13%	11%	11%	14%	5%	8%	12%	17%
Total Debt to Total Assets (%)	19%	7%	9%	18%	18%	18%	19%	21%	21%	19%
Debt/Equity Ratio (%)	8.3%	0.3%	4%	8%	11%	15%	17%	19%	14%	9%
Return on Assets (%)	9%	10%	11%	9%	9%	11%	4%	6%	9%	13%
Asset Turnover (%)	7%	10%	20%	16%	7%	10%	8%	9%	7%	6%
Dividend Payout Ratio (%)	46%	44%	42%	10%	10%	9%	21%	18%	16%	8%

DEFINITION OF FINANCIAL TERMS

Net Asset Value Per Share

Equity Attributable to Equity Holders of the Parent divided by the weighted average number of ordinary shares in issue.

Current Ratio

Total Current Assets divided by Total Current Liabilities.

Asset Turnover

Total Revenue divided by Total Average Assets.

Return on Equity

Profit Attributable to Equity Holders divided by Average Equity Attributable to Equity Holders of the Parent.

Total Debt to Total Assets

Total Non-Current Liabilities and Total Current Liabilities divided by Total Assets.

Debt/Equity Ratio

Total Interest Bearing Loans and Borrowing divided by Equity Attributable to Equity Holders of the Parent.

Shareholder Information

1. STATED CAPITAL

	31st December 2016	31st December 2015
Issued and Fully paid Capital (Rs.)	11,162,751,513	11,162,751,513
No of Shares	887,878,273	887,878,273
Class of Shares	Ordinary Shares	
Voting Rights	One Vote per Ordinary Share	

2. STOCK EXCHANGE LISTING

The issued ordinary shares of Overseas Realty (Ceylon) PLC, are listed with the Colombo Stock Exchange of Sri Lanka.

3. ORDINARY SHAREHOLDERS AS AT 31ST DECEMBER 2016

The number of Share Holders as at 31st December 2016 was 3,917 (As at 31st December 2015 - 4,361).

Shareholdings	Resident		Non Resident		Total	
	No. of Shareholders	Percentage (%)	No. of Shareholders	Percentage (%)	No. of Shareholders	Percentage (%)
1 - 1,000	2,198	0.08%	19	0.00%	2,217	0.08%
1,001 - 10,000	1,184	0.52%	21	0.01%	1,205	0.53%
10,001 - 100,000	378	1.24%	18	0.07%	396	1.31%
100,001 - 1,000,000	66	2.25%	16	0.56%	82	2.81%
Over 1,000,000	9	4.63%	8	90.64%	17	95.27%
	3,835	8.72%	82	91.28%	3,917	100.00%

Categories of Shareholders

Category	As of 31 December 2016		As of 31 December 2015	
	No. of Shareholders	No. of Shares	No. of Shareholders	No. of Shares
Individual	3,675	33,213,051	4,076	37,400,817
Institutional	242	854,665,222	285	850,477,456
	3,917	887,878,273	4,361	887,878,273

4. SHARE TRADING INFORMATION

	31 December 2016		31 December 2015	
	Date	Price (Rs.)	Date	Price (Rs.)
Highest	25.04.2016	26.10	12.01.2015	29.00
Lowest	29.11.2016	19.30	30.10.2015	20.50
Closing Price	31.12.2016	20.00	31.12.2015	23.20
			31 December 2016	31 December 2015
Number of Transactions			4,930	10,761
Number of Shares Traded			40,281,635	47,088,195
Value of Shares Traded (Rs.)			969,142,470	1,118,750,285

5. DIVIDENDS

	31 December 2016	31 December 2015
Dividends Per Share (Rs.)	1.50	1.50
Dividend Payout (%)	45.7	43.6

6. DIRECTOR'S SHAREHOLDINGS

The Shareholding of the Directors at the beginning and at the end of the year was as follows:

Name of Director	31st December 2016 No of Shares	31st December 2015 No of Shares
Mr. Shing Pee Tao	Nil	Nil
Mr. Yap Boh Pin	Nil	Nil
Mrs. Mildred Tao Ong	Nil	Nil
Mr. Hussein Zubire Cassim	Nil	Nil
Mr. En Ping Ong	400,000	400,000
Mrs. Rohini Letitia Nanayakkara	Nil	Nil
Mr. Ajith Mahendra De Silva Jayaratne	Nil	Nil
Mr. Leslie Ralph De Lanerolle	Nil	Nil
Mr. Tissa Kumara Bandaranayake	Nil	Nil
Dr. Ranee Jayamaha	Nil	Nil
Mr. Pravir Dhanoush Samarasinghe	Nil	Nil

Shareholder Information

7. TOP TWENTY SHAREHOLDERS AS AT 31ST DECEMBER

NAME	As at 31st Dec 2016		As at 31st Dec 2015	
	Shareholding	Percentage (%)	Shareholding	Percentage (%)
1 SHING KWAN INVESTMENT COMPANY LIMITED.	477,655,116	53.8	477,655,116	53.8
2 UNITY BUILDERS LIMITED	231,951,090	26.12	231,951,090	26.12
3 PERSHING LLC S/A AVERBACH GRAUSON & CO.	44,314,470	4.99	34,810,898	3.92
4 SHING KWAN INVESTMENT (SINGAPORE) PTE LTD	22,729,218	2.56	22,729,218	2.56
5 PEOPLES BANK	21,813,003	2.46	21,813,003	2.46
6 SHING KWAN (PTE.) LTD	16,200,000	1.82	-	-
7 CHIPPERFIELD INVESTMENTS LIMITED	8,075,052	0.91	8,075,052	0.91
8 SRI LANKA INSURANCE CORPORATION LTD-LIFE FUND	4,649,218	0.52	4,649,218	0.52
9 BANK OF CEYLON-NO2 A/C	3,971,842	0.45	3,971,842	0.45
10 DEUTSCHE BANK AG AS TRUSTEE FOR JB.V.V.E FUND	3,099,550	0.35	3,099,550	0.35
11 ORIENTAL PEARL INTERNATIONAL INC	2,684,210	0.3	2,684,210	0.30
12 E.W. BALASURIYA & CO. (PVT) LTD	2,260,992	0.25	2,260,992	0.25
13 SEYLAN BANK PLC/SYMPHONY CAPITAL LTD	1,567,658	0.18	1,942,158	0.22
14 DR. SENTHILVERL THIRUGNANASAMBANDAR	1,535,694	0.17	-	-
15 MR. SUBASINGHE	1,154,039	0.13	1,071,059	0.12
16 MR. GAUTAM RAHUL	1,120,000	0.13	1,110,002	0.13
17 MR. WEERASINGHE	1,054,834	0.12	1,054,834	0.12
18 BANK OF CEYLON NO. 1 ACCOUNT	952,792	0.11	-	-
19 NATIONAL SAVINGS BANK	943,473	0.11	-	-
20 GOLD INVESTMENT LIMITED	929,157	0.1	-	-
TOTAL	848,661,408	95.58	818,878,242	92.23
Balance held by other Shareholders	39,216,865	4.42	69,000,031	7.77
Total number of Ordinary Shares	887,878,273	100.00	887,878,273	100.00
Public Holding	138,942,849	15.65	155,142,849	17.47
Others	748,935,424	84.35	732,735,424	82.53
Total	887,878,273	100.00	887,878,273	100.00

8. PUBLIC SHAREHOLDING

	31st December 2016 No. of Shares	31st December 2015 No. of Shares
Parent/Group/Subsidiary		
Shing Kwan Investments Company Limited	477,655,116	477,655,116
Unity Builders Limited	231,951,090	231,951,090
Shing Kwan Investment (Singapore) Pte Ltd	22,729,218	22,729,218
Shing Kwan (Pte) Ltd	16,200,000	-
	748,535,424	732,335,424
Issued number of ordinary shares as at 31 December	887,878,273	887,878,273
Less		
Parent/Group	477,655,116	477,655,116
Subsidiaries or Associate Companies of Parent	270,880,308	254,680,308
Over 10% Holding	-	-
Directors' Shareholding	400,000	400,000
Spouses of Directors and CEO	-	-
Public Holding	138,942,849	155,142,849
Public Holding as a percentage of Issued Ordinary Shares	15.65%	17.47%

Group Land Portfolio

Location	Land Extent			Market Value Rs. Mn	Category
	A.	R.	P.		
Echelon Squire, Colombo 01.	2	0	0	5,440	Investment Property
WTC Building					
No 34, Havelock City, Colombo 06.	-	3	22	568	Property Plant & Equipment
Clubhouse Building					
No 34, Havelock City, Colombo 06.	13	2	19	8,730	Inventory –Long term Assets

Notice of Meeting

Notice is hereby given that the Thirty- Fifth (35th) Annual General Meeting of OVERSEAS REALTY (CEYLON) PLC will be held on Monday, 24th April 2017 at 3.30 p.m. at the Havelock City Club House, No. 324, Havelock Road, Colombo 06, for the transaction of the following business:

AGENDA

1. To receive and consider the Report of the Board of Directors and the Financial Statement as at 31st December 2016 and the Report of the Auditors thereon.

2. To declare a First and Final Dividend of Rs.1.25 per Ordinary Share in respect of the financial year ending 31st December 2016 as recommended by the Directors.

3. i) Ordinary Resolution

That the age limit of 70 years referred to in Section 210 of the Companies Act No. 07 of 2007 shall not apply to SHING PEE TAO who attained the age of 70 years on 25th December 1986 and that he be re-elected as a Director of the Company.

ii) Ordinary Resolution

That the age limit of 70 years referred to in Section. 210 of the Companies Act No. 07 of 2007 shall not apply to HUSSAIN ZUBIRE CASSIM who attained the age of 70 years on 9th September 1995 and that he be re-elected as a Director of the Company.

iii) Ordinary Resolution

That the age limit of 70 years referred to in Section 210 of the Companies Act No. 07 of 2007 shall not apply to ROHINI LETTITIA NANAYAKKARA, who attained the age of 70 years on 12th April 2006 and that she be re-elected as a Director of the Company.

iv) Ordinary Resolution

That the age limit of 70 years referred to in Section 210 of the Companies Act No. 07 of 2007 shall not apply to AJIT MAHENDRA DE SILVA JAYARATNE, who attained the age of 70 years on 30th April 2010 and that he be re-elected as a Director of the Company.

v) Ordinary Resolution

That the age limit of 70 years referred to in Section 210 of the Companies Act No. 07 of 2007 shall not apply to YAP BOH PIN, who attained the age of 70

years on 2nd February 2011 and that he be re-elected as a Director of the Company.

vi) Ordinary Resolution

That the age limit of 70 years referred to in Section 210 of the Companies Act No. 07 of 2007 shall not apply to TISSA KUMARA BANDARANAYAKE, who attained the age of 70 years on 3rd January 2013 and that he be re-elected as a Director of the Company.

vii) Ordinary Resolution

That the age limit of 70 years referred to in Section 210 of the Companies Act No. 07 of 2007 shall not apply to LESLEI RALPH DE LANEROLLE, who attained the age of 70 years on 5th January 2013 and that he be re-elected as a Director of the Company.

4. To re-appoint Messrs. Ernst & Young, Chartered Accountants, as Auditors to the Company and to authorize the Directors to determine their remuneration.

By Order of the Board
Overseas Realty (Ceylon) Plc.

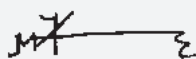

Minoka S. Fernando
Company Secretary

Colombo on this 24th March 2017

Corporate Information

Name of the Company

Overseas Realty (Ceylon) PLC

Company Registration No.

PQ39

Legal Form

A Public Listed Company with limited liability, incorporated in Sri Lanka on 28th October, 1980 under the Companies Ordinance (Cap.145) bearing Company Registration No. PBS1084 and listed on the Colombo Stock Exchange since 1982. The Company was re-registered under the Companies Act No. 07 of 2007.

Registered Office

Overseas Realty (Ceylon) PLC
Level 18–East Tower
World Trade Center
Echelon Square
Colombo 01
Tel: 2346333

Directors

Shing Pee Tao – Chairman
Hussein Zubire Cassim – Deputy Chairman
Tissa Kumara Bandaranayake
Ajit Mahendra De Silva Jayaratne
Leslie Ralph de Lanerolle
Rohini Lettitia Nanayakkara
Mildred Tao Ong
Melvin Yap Boh Pin
En Ping Ong
Ranee Jayamaha
Pravir Samarasinghe

Tao Ben Nien (alternate to Shing Pee Tao)
Lee Kang Ho (alternate to Melvin Yap Boh Pin)

Audit Committee

Ajit Mahendra De Silva Jayaratne – Chairman
Hussein Zubire Cassim
Melvin Yap Boh Pin
Rohini Lettitia Nanayakkara
Tissa Kumara Bandaranayake

Remuneration Committee

Hussein Zubire Cassim
Rohini Lettitia Nanayakkara
Ajit Mahendra De Silva Jayaratne
En Ping Ong
Tissa Kumara Bandaranayake

Group Management Committee

Pravir Samarasinghe
Elmo Fernando
Roschen Perera
Minoka Fernando
Remaz Ghouse
Indradeva Mendis
Yamuna Jayaratne
Yasheela Amarawardena
Shanesh Ratnaweera

Company Secretary

Minoka Fernando
Attorney-at-Law

Auditors

Messrs. Ernst & Young
201, De Saram Place
Colombo 10
Tel: 2463500

Registrars

Messrs. SSP Corporate Services (Private) Limited
101, Inner Flower Road
Colombo 03
Tel: 2573894

Subsidiaries

Mireka Capital Land (Private) Limited
Mireka Homes (Private) Limited
Havelock City (Private) Limited
SK Investments Lanka (Private) Limited [Now known as Overseas Realty Investment Lanka (Private) Limited]
Mireka Rescidencies (Private) Limited
Mireka Property (Private) Limited
Realty Management Services (Private) Limited

Level 18–East Tower
World Trade Center
Echelon Square
Colombo 01
Tel: 2346333/2502247/2505100

Websites

www.orcl.lk
www.wtc.lk
www.havelockcity.lk



Designed & produced by REDWORKS
Digital plates & Printed by Printage (Pvt) Ltd



OVERSEAS REALTY [CEYLON] PLC

18, East Tower, World Trade Center, Echelon Square Colombo 01, Sri Lanka.